



Instruction and  
warning book 

# VICTRIX Superior TOP 32 E

\*1.032471IE\*



**Dear Client,**

Our compliments for having chosen a top-quality Immergas product, able to assure well-being and safety for a long period of time. As an Immergas customer you can also count on a qualified after-sales service, prepared and updated to guarantee constant efficiency of your boiler. Read the following pages carefully: you will be able to draw useful suggestions regarding the correct use of the appliance, the respect of which, will confirm your satisfaction for the Immergas product. Contact our area authorised after-sales centre as soon as possible to request commissioning. Our technician will verify the correct functioning conditions; he will perform the necessary calibrations and will demonstrate the correct use of the generator.

For any interventions or routine maintenance contact Immergas Authorised Centres: these have original spare parts and boast of specific preparation directly from the manufacturer.

**General recommendations**

The instruction book is an integral and essential part of the product and must be consigned to the new user also in the case of transfer or succession of ownership. It must be stored with care and consulted carefully, as all of the warnings provide important safety indications for installation, use and maintenance stages.

In compliance with legislation in force, the systems must be designed by qualified professionals, within the dimensional limits established by the Law. Installation and maintenance must be performed in compliance with the regulations in force, according to the manufacturer's instructions and by professionally qualified staff, intending staff with specific technical skills in the plant sector, as envisioned by the Law.

Incorrect installation can cause injury to persons and animals and damage to objects, for which the manufacturer is not liable. Maintenance must be carried out by skilled technical staff. The Immergas Authorised After-sales Service represents a guarantee of qualifications and professionalism.

The appliance must only be destined for the use for which it has been expressly declared. Any other use will be considered improper and therefore potentially dangerous. If errors occur during installation, operation and maintenance, due to non compliance with technical laws in force, standards or instructions contained in this book (or however supplied by the manufacturer), the manufacturer is excluded from any contractual and extra-contractual liability for any damages and the appliance warranty is invalidated. For further information regarding legislative and statutory provisions relative to the installation of gas heat generators, consult the Immergas site at the following address: [www.immergas.com](http://www.immergas.com).

**DECLARATION OF CONFORMITY**

For the purpose and effect of the 2009/142/CE Gas Appliance Directive, 2004/108/CE EMC Directive, 92/42/CE Efficiency Directive and 2006/95/CE Low Voltage Directive.

The Manufacturer: Immergas S.p.A. v. Cisa Ligure n° 95 42041 Brescello (RE)

Mauro Guareschi

Research & Development Director

DECLARES THAT: the Immergas boiler model:

**Victrix Superior TOP 32 E**

is in compliance with the same European Community Directives

Signature:



**INDEX**

INSTALLER		USER		MAINTENANCE TECHNICIAN	
	page		page		page
1	Boiler installation.....	2	Instructions for use and Maintenance. ....	3	Boiler commissioning (initial check).....
1.1	Installation recommendations. ....	2.1	Cleaning and maintenance. ....	3.1	Hydraulic Diagram.....
1.2	Main dimensions. ....	2.2	General warnings.....	3.2	Wiring diagram.....
1.3	Anti-freeze protection.....	2.3	Control panel.....	3.3	Troubleshooting.....
1.4	Connection unit (supplied as standard with the boiler).....	2.4	Description of functioning states. ....	3.4	Converting the boiler to other types of gas...27
1.5	Remote controls and room chrono-thermostats (Optional). ....	2.5	Using the boiler. ....	3.5	Calibration of number of fan revs. ....
1.6	External temperature probe (Optional).....	2.6	Fault and anomaly signals.....	3.6	Adjustment of the air-gas ratio. ....
1.7	Immergas flue systems. ....	2.7	Boiler shutdown.....	3.7	Checks following conversion to another type of gas.....
1.8	Tables of Resistance Factors and Equivalent Lengths. ....	2.8	Restore heating system pressure. ....	3.8	Programming the P.C.B.....
1.9	Outdoor installation in partially protected area. ....	2.9	Draining the system.....	3.9	"Chimney sweep function".....
1.10	Horizontal concentric kit installation. ....	2.10	Anti-freeze protection. ....	3.10	Pump anti-block function. ....
1.11	Vertical concentric kit installation. ....	2.11	Case cleaning.....	3.11	three-way anti-block function.....
1.12	Separator kit installation.....	2.12	Decommissioning.....	3.12	Radiators anti-freeze function. ....
1.13	Adapter kit installation C9. ....	2.13	Parameters and information menu. ....	3.13	P.C.B. periodical self-check. ....
1.14	Ducting of flues or technical slots. ....			3.14	Automatic vent function.....
1.15	Configuration type B <sub>23</sub> open chamber and forced draught for inside.....			3.15	Solar panels coupling function. ....
1.16	Flue exhaust to flue/chimney.....			3.16	Yearly control and maintenance of the appliance. ....
1.17	Flues, chimneys, chimney caps and terminals. ....			3.17	Casing removal.....
1.18	System filling. ....			3.18	Variable heat power. ....
1.19	Filling the condensate trap. ....			3.19	Combustion parameters. ....
1.20	Gas system start-up. ....			3.20	Technical data.....
1.21	Boiler start up (ignition).....				
1.22	Circulation pump.....				
1.23	Kits available on request. ....				
1.24	Boiler components.....				

Immergas S.p.A. declines all liability due to printing or transcription errors, reserving the right to make any modifications to its technical and commercial documents without forewarning.

# 1 BOILER INSTALLATION

## 1.1 INSTALLATION RECOMMENDATIONS.

The Victrix Superior TOP I boiler has been designed for wall mounted installation only; for heating environments and production of domestic hot water for domestic use and similar purposes.

The wall surface must be smooth, without any protrusions or recesses enabling access to the rear part. They are not designed to be installed on plinths or floors (Fig. 1-1).

By varying the type of installation the classification of the boiler also varies, precisely:

- **Type B23 boiler** if installed using the relevant terminal for air intake directly from the room in which the boiler has been installed.
- **Type C boiler** if installed using concentric pipes or other types of pipes envisioned for the sealed chamber boiler for intake of air and expulsion of fumes.

Only professionally enabled heating/plumbing technicians are authorised to install Immergas gas appliances.

Installation must be carried out according to regulation standards, current legislation and in compliance with local technical regulations and the required technical procedures.

Before installing the appliance, ensure that it is delivered in perfect condition; if in doubt, contact the supplier immediately. Packing materials (staples, nails, plastic bags, polystyrene foam, etc.) constitute a hazard and must be kept out of the reach of children. If the appliance is installed inside or between cabinets, ensure sufficient space for normal servicing; therefore it is advisable to leave clearance of at least 3 cm between the boiler casing and the vertical sides of the cabinet. Leave adequate space above the boiler for possible water and flue removal connections. Keep all flammable objects away from the appliance (paper, rags, plastic, polystyrene, etc.).

Do not place household appliances underneath the boiler as they could be damaged if the safety valve intervenes with the blocked conveyor system (remember that the safety valve must always be conveyed away by a draining funnel), or if there are leaks from the hydraulic connections; on the contrary, the manufacturer cannot be held responsible for any damage caused to the household appliances.

It is also advisable, to not position furnishings, furniture, etc., under the boiler for the above mentioned reasons.

In the event of malfunctions, faults or incorrect operation, turn the appliance off immediately and contact a qualified technician (e.g. the Immergas Technical Assistance centre, which has specifically trained staff and original spare parts) Do not attempt to modify or repair the appliance alone.

Failure to comply with the above implies personal responsibility and invalidates the warranty.

### • Installation Standards:

- This boiler can be installed outdoors in a partially protected area. A partially protected area is one in which the appliance is not exposed to the direct action of the weather (rain, snow, hail, etc...).
- Installation in places with a fire risk is prohibited (for example: garages, box), gas appliances and relative flue ducts, flue exhaust pipes and combustion air intake pipes.
- Installation is prohibited on the vertical projection of the cooking surface.
- Installation is also prohibited in places/environments that constitute common parts of office condominiums such as stairs, cellars, entrance halls, attics, lofts, escape routes, etc. if they are not located inside technical compartments under the responsibility of each individual building and only accessible to the user (for the features of the technical compartments, see the current technical regulations).

**Important:** wall mounting of the boiler must guarantee stable and efficient support for the generator.

*The plugs (standard supply) are to be used only in conjunction with the mounting brackets or fixing template to fix the appliance to the wall; they only ensure adequate support if inserted correctly (according to technical standards) in walls made of solid or semi-hollow brick or block. In the case of walls made from hollow brick or block, partitions with limited static properties, or in any case walls other than those indicated, a static test must be carried out to ensure adequate support.*

**N.B.: the hex head screws supplied in the blister pack are to be used exclusively to fix the relative mounting bracket to the wall.**

These boilers are used to heat water to below boiling temperature in atmospheric pressure. They must be connected to a central heating system and hot water circuit suited to their performance and capacity.

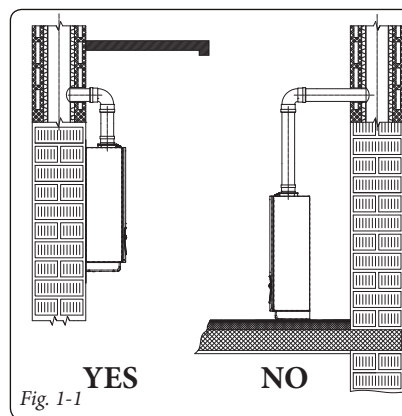

INSTALLER

USER

MAINTENANCE TECHNICIAN

## 1.2 MAIN DIMENSIONS.

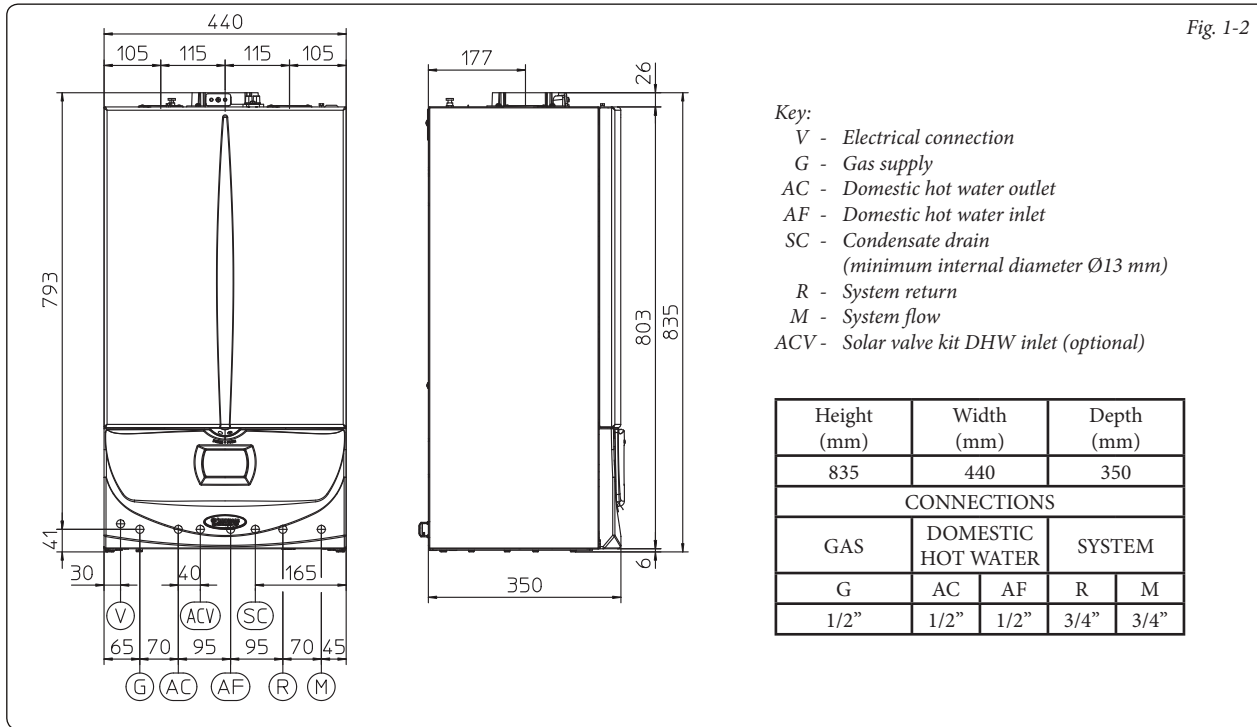

## 1.3 ANTI-FREEZE PROTECTION.

**Minimum temperature -3°C.** The boiler comes standard with an anti-freeze function that activates the pump and burner when the system water temperature in the boiler falls below 4°C. The anti-freeze function is only guaranteed if:

- the boiler is correctly connected to gas and electricity power supply circuits;
- the boiler is powered constantly;
- the boiler is not in stand-by (⏻);
- the boiler is not in no ignition block (par. 2.6);
- the boiler essential components are not faulty.

*In these conditions the boiler is protected against freezing to an environmental temperature of -3°C.*

**Minimum temperature -15°C.** If the boiler is installed in a place where the temperature falls below -5°C and in the event there is no gas (or the boiler goes into ignition block), the appliance can freeze.

*To prevent the risk of freezing follow the instructions below:*

- protect the central heating circuit from freezing by introducing a top quality anti-freeze liquid into this circuit, which is not noxious to health. The instructions of the manufacturer of this liquid must be followed scrupulously regarding the percentage necessary with respect to the minimum temperature at which the system must be kept. An aqueous solution must be made with potential pollution class of water 2.

*The materials used for the central heating circuit of Immergas boilers resist ethylene and propylene glycol based antifreeze liquids (if the mixtures are prepared perfectly).*

For life and possible disposal, follow the supplier's instructions.

- Protect the condensate drain trap and circuit board against freezing by using an accessory that is supplied on request (anti-freeze kit) comprising two electric heating elements, the relevant cables and a control thermostat (carefully read the installation instructions contained in the accessory kit pack).

*Boiler anti-freeze protection is thus ensured only if:*

- the boiler is correctly connected to gas and electricity power supply circuits and powered;
- the anti-freezing kit components are efficient.

*In these conditions the boiler is protected against freezing to temperature of -15°C.*

*The warranty does not cover damage due to interruption of the electrical power supply and failure to comply with that stated on the previous page.*

**N.B.:** if the boiler is installed in places where the temperature falls below 0°C the domestic water and heating attachment pipes must be insulated.

#### 1.4 CONNECTION UNIT (SUPPLIED AS STANDARD WITH THE BOILER).

**Gas connection (Appliance category II<sub>2H3B/P</sub>).** Our boilers are designed to operate with methane gas (G20) and LPG. Supply pipes must be the same as or larger than the 1/2" G boiler fitting. Before connecting the gas line, carefully clean inside all the fuel feed system pipes to remove any residue that could impair boiler efficiency. Also make sure the gas corresponds to that for which the boiler is prepared (see boiler data-plate). If different, the appliance must be converted for operation with the other type of gas (see converting appliance for other gas types). The dynamic gas supply (methane or LPG) pressure must also be checked according to the type used in the boiler, which must be in compliance, as insufficient levels can reduce generator output and cause malfunctions.

Ensure correct gas cock connection. The gas supply pipe must be suitably dimensioned according to current regulations in order to guarantee correct gas flow to the burner even in conditions of maximum generator output and to guarantee appliance efficiency (technical specifications). The coupling system must conform to standards.

**Fuel gas quality.** The appliance has been designed to operate with gas free of impurities; otherwise it is advisable to fit special filters upstream from the appliance to restore the purity of the gas.

**Storage tanks (in case of supply from LPG depot).**

- New LPG storage tanks may contain residual inert gases (nitrogen) that degrade the mixture delivered to the appliance causing functioning anomalies.
- Due to the composition of the LPG mixture, layering of the mixture components may occur during the period of storage in the tanks. This can cause a variation in the heating power of the mixture delivered to the appliance, with subsequent change in its performance.

#### Hydraulic connection.

**Attention:** In order not to void the warranty before making the boiler connections, carefully clean the heating system (pipes, radiators, etc.) with special pickling or de-scaling products to remove any deposits that could compromise correct boiler operation.

A chemical treatment for the thermal system water is prescribed according to the current technical regulations, until the system and the lime scale apparatus is preserved (for example, limescale deposits), from the slurry formation and other noxious deposits.

Water connections must be made in a rational way using the couplings on the boiler template. The boiler safety valve outlet must be connected to a draining funnel. Otherwise, the manufacturer declines any responsibility in case of flooding if the drain valve cuts in.

**Important:** to preserve the duration of appliance efficiency features, in the presence of water whose features can lead to the deposit of lime scale, installation of the "polyphosphate dispenser" kit is recommended.

**Condensate drain.** To drain the condensate produced by the appliance, it is necessary to connect to the drainage system by means of acid condensate resistant pipes having an internal diameter of at least 13 mm. The system connecting the appliance to the drainage system must be carried out in such a way as to prevent freezing of the liquid contained in it. Before appliance start-up, ensure that the condensate can be correctly removed. Also, comply with national and local regulations on discharging waste waters.

**Electrical connection:** The "Victrix Superior TOP" boiler has an IPX5D protection rating for the entire appliance. Electrical safety of the appliance is reached only when it is correctly connected to an efficient earthing system as specified by current safety standards.

**Attention:** Immergas S.p.A. declines any responsibility for damage or physical injury caused by failure to connect the boiler to an efficient earth system or failure to comply with the reference standards.

Also ensure that the electrical installation corresponds to maximum absorbed power specifications as shown on the boiler data-plate. Boilers are supplied complete with an "X" type power cable without plug. The power supply cable must be connected to a 230V ±10% / 50Hz mains supply respecting L-N polarity and earth connection . This network must also have an omnipolar circuit breaker with class III over-voltage category.

To protect against possible voltage dispersions, it is necessary to envision a differential safety device type A.

When replacing the power supply cable, contact a qualified technician (e.g. the Immergas After-Sales Technical Assistance Service). The power cable must be laid as shown (Fig. 1-3).

In the event of mains fuse replacement on the P.C.B., use a 3.15A quick-blow fuse. For the main power supply to the appliance, never use adapters, multiple sockets or extension leads.

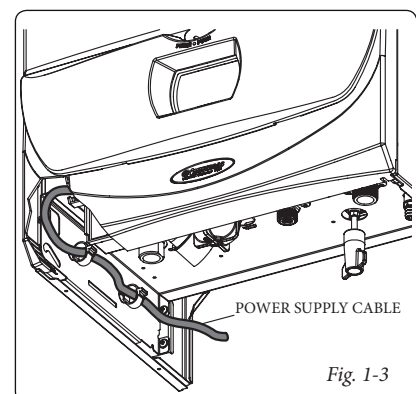

Fig. 1-3

## 1.5 REMOTE CONTROLS AND ROOM CHRONO-THERMOSTATS (OPTIONAL).

The boiler is prepared for the application of room chrono-thermostats or remote controls, which are available as optional kits.

All Immergas chrono-thermostats are connected with 2 wires only. Carefully read the user and assembly instructions contained in the accessory kit.

- On/Off digital chrono-thermostat (Fig. 1-4). The chrono-thermostat allows:
  - to set two room temperature values: one for day (comfort temperature) and one for night (lower temperature);
  - set a weekly program with four daily switch-on/off;
  - selecting the required function mode from the various possible alternatives:
    - manual operation (with adjustable temperature).
    - automatic operation (with set program).
    - forced automatic operation (temporarily modifying the temperature of the automatic program).

The chrono-thermostat is powered by two 1.5V LR 6 type alkaline batteries.

- There are two types of remote controls available: Comando Amico Remoto remote control  $V^2$  (CAR $V^2$ ) (Fig. 1-4) and Super Comando Amico Remoto remote control (Super CAR) (Fig. 1-5) both with room chrono-thermostat functioning. In addition to the functions described in the previous point, the chrono-thermostat panels enable the user to control all the important information regarding operation of the appliance and the central heating system with the opportunity of easily intervening on the previously set parameters without having to go to the place where the appliance is installed. The panel is provided with self-diagnosis to display any boiler functioning anomalies.

The climate chrono-thermostat incorporated into the remote panel enables the system flow temperature to be adjusted to the actual needs of the room being heated, in order to obtain the desired room temperature with extreme precision and therefore with evident saving in running costs. The chrono-thermostat is fed directly by the boiler by means of the same 2 wires used for the transmission of data between boiler and chrono-thermostat.

**Important:** if the system is subdivided into zones using the relevant kit, the CAR  $V^2$  and the Super CAR must be used with its climate thermostat function disabled, i.e. it must be set to On/Off mode.

### CAR $V^2$ , Super CAR or On/Off chrono-thermostat electrical connection (Optional).

The operations described below must be performed after having removed the voltage from the appliance. The eventual On/Off environment chrono-thermostat must be connected to clamps 40 and 41 eliminating jumper X40 (Fig. 3-2). Make sure that the On/Off thermostat contact is of the "clean" type, i.e. independent of the mains supply, otherwise the P.C.B. would be damaged. Any CAR $V^2$  or Super CAR must be connected by means of terminals IN+ and IN- to terminals 42 and 43 on the circuit board, eliminating jumper X40 and respecting polarity (Fig. 3-2). Connection with the wrong polarity prevents functioning, but without damaging the Remote control. The boiler can only be connected to one remote control.

**Important:** if the Comando Remoto remote control is used, arrange two separate lines in compliance with current regulations regarding electrical systems. No boiler pipes must ever be used to earth the electric system or telephone lines. Ensure elimination of this risk before making the boiler electrical connections.

**Installation with system operating at direct low temperature.** The boiler can directly feed a low temperature system by acting on parameter "P66" (Par. 3.8) and setting the flow temperature adjustment range "P66/A" and "P66/B". In this situation it is good practice to insert a safety device in series with the power supply and boiler. This device is made up from a thermostat with a temperature limit of 60°C. The thermostat must be positioned on the system delivery pipe at a distance of at least 2 metres from the boiler.

## 1.6 EXTERNAL TEMPERATURE PROBE (OPTIONAL).

The boiler is prepared for the application of the external probe (Fig. 1-6), which is available as an optional kit. Refer to the relative instruction sheet for positioning of the external probe. The probe can be connected directly to the boiler electrical system and allows the max. system flow temperature to be automatically decreased when the external temperature increases, in order to adjust the heat supplied to the system according to the change in external temperature. The external probe always operates when connected, regardless of the presence or type of room chrono-thermostat used and can work in combination with Immergas timer thermostats. The correlation between system flow temperature and external temperature is determined by the parameters set in menu "M5" under "P66" according to the curves represented in the diagram (Fig. 1-7). The electric connection of the external probe must be made on clamps 38 and 39 on the boiler P.C.B. (Fig. 3-2).

Comando Amico Remoto remote control $V^2$  (CAR $V^2$ )  
On/Off digital chrono-thermostat.

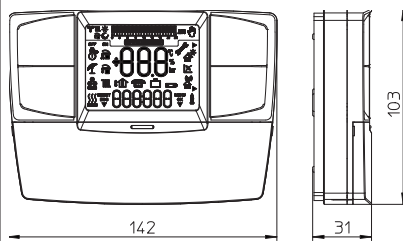

Fig. 1-4

Super Comando Amico Remoto  
remote control (Super CAR)

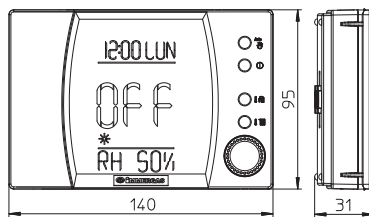

Fig. 1-5

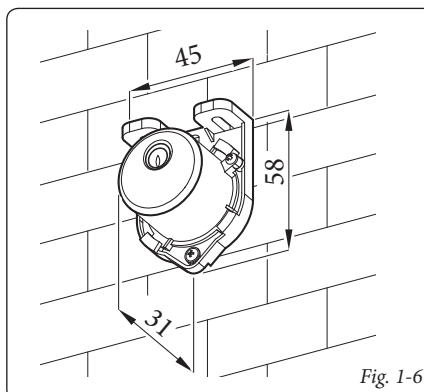
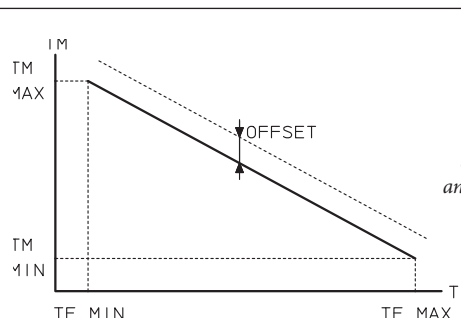

Fig. 1-6



$TM-MAX/MIN$  = Selected flow temp. range.  
 $TE$  = External temperature.

**EXTERNAL PROBE**  
Correction law of the flow temperature depending on the external temperature and user adjustments of the central heating temperature.

Fig. 1-7

**1.7 IMMERGAS FLUE SYSTEMS.**

Immergas supplies various solutions separately from the boilers regarding the installation of air intake terminals and flue extraction, which are fundamental for boiler operation.

**Attention: the boiler must be installed exclusively with an original Immergas “Green Range” air intake and fume extraction system in plastic, as envisioned by Standard in force.**

**The plastic pipes cannot be installed outdoors, for tracts longer than 40 cm, without suitable protection from UV rays and other atmospheric agents.**

**This system can be identified by an identification mark and special distinctive marking bearing the note: “only for condensing boilers”.**

• Resistance factors and equivalent lengths. Each flue component has a *Resistance Factor* based on experimental tests and specified in the table below. The Resistance Factor for individual components is independent from the type of boiler on which it is installed and has a dimensionless size. It is however, conditioned by the temperature of the fluids that pass through the pipe and therefore, varies according to applications for air intake or flue exhaust. Each single component has a resistance corresponding to a certain length in metres of pipe of the same diameter; the so-called *equivalent length*, obtained from the ratio between the relative Resistance Factors. *All boilers have an experimentally obtainable maximum Resistance Factor equal to 100.* The maximum Resistance Factor allowed corresponds to the resistance encountered with the maximum allowed pipe length for each type of Terminal Kit. This information allows calculations to be made to verify the possibility of setting up various flue configurations.

• **Positioning of the gaskets (black) for “green range” flue extraction systems.** Position the gasket correctly (for bends and extensions) (Fig. 1-8):

- gasket (A) with notches, to use for bends;
- gasket (B) without notches, to use for extensions.

**N.B.:** if component lubrication (already carried out by the manufacturer) is not sufficient, remove the residual lubricant using a dry cloth, then to ease fitting spread the elements with common or industrial talc.

- Coupling extension pipes and concentric elbows. To install push-fitting extensions with other elements of the flue, proceed as follows: Install the concentric pipe or elbow with the male side (smooth) on the female section (with lip seal) to the end stop on the previously installed element in order to ensure sealing efficiency of the coupling.

**Attention:** if the exhaust terminal and/or extension concentric pipe needs shortening, consider that the internal duct must always protrude by 5 mm with respect to the external duct.

- **N.B.:** for safety purposes, do not obstruct the boiler intake-exhaust terminal, even temporarily.
- **N.B.:** when installing horizontal pipes, a minimum inclination of 3% must be maintained and a section clamp with pin must be installed every 3 metres.

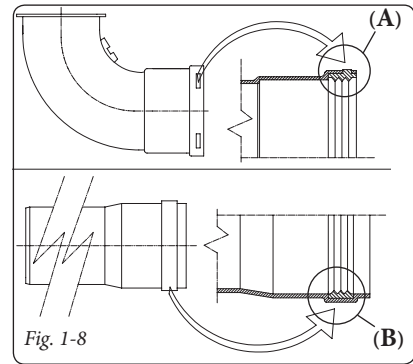
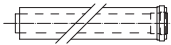

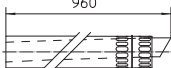

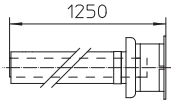
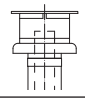
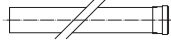
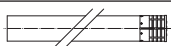



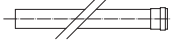

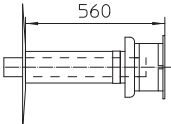

Fig. 1-8

**1.8 TABLES OF RESISTANCE FACTORS AND EQUIVALENT LENGTHS.**

TYPE OF DUCT		Resistance Factor (R)	Equivalent length in m of concentric pipe Ø80/125
Concentric pipe Ø80/125 m 1		2.1	1
Concentric bend 90° Ø80/125		3.0	1.4
Concentric bend 45° Ø80/125		2.1	1
Terminal complete with concentric horizontal intake-exhaust Ø80/125		2.8	1.3
Terminal complete with concentric vertical intake-exhaust Ø80/125		3.6	1.7
Concentric bend 90° Ø80/125 with inspection		3.4	1.6
Stub pipe with inspection Ø80/125		3.4	1.6

TYPE OF DUCT		Resistance Factor (R)	Equivalent length in m of concentric pipe Ø60/100	Equivalent length in metres of pipe Ø80	Equivalent length in metres of pipe Ø60	Equivalent length in m of concentric pipe Ø80/125
Concentric pipe Ø60/100 m 1		Intake and Exhaust 6.4	<b>m 1</b>	Intake m 7.3	Exhaust m 1.9	m 3.0
				Exhaust m 5.3		
Concentric bend 90° Ø60/100		Intake and Exhaust 8.2	<b>m 1.3</b>	Intake m 9.4	Exhaust m 2.5	m 3.9
				Exhaust m 6.8		
Concentric bend 45° Ø60/100		Intake and Exhaust 6.4	<b>m 1</b>	Intake m 7.3	Exhaust m 1.9	m 3.0
				Exhaust m 5.3		
Terminal complete with concentric horizontal intake-exhaust Ø60/100		Intake and Exhaust 15	<b>m 2.3</b>	Intake m 17.2	Exhaust m 4.5	m 7.1
				Exhaust m 12.5		
Concentric horizontal intake- exhaust terminal Ø60/100		Intake and Exhaust 10	<b>m 1.5</b>	Intake m 11.5	Exhaust m 3.0	m 4.7
				Exhaust m 8.3		
Terminal complete with concentric vertical intake-exhaust Ø60/100		Intake and Exhaust 16.3	<b>m 2.5</b>	Intake m 18.7	Exhaust m 4.9	m 7.7
				Exhaust m 13.6		
Concentric vertical intake-exhaust terminal Ø60/100		Intake and Exhaust 9	<b>m 1.4</b>	Intake m 10.3	Exhaust m 2.7	m 4.3
				Exhaust m 7.5		
Pipe Ø80, 1 m		Intake 0.87 Exhaust 1.2	m 0.1 m 0.2	<b>Intake m 1.0</b>	Exhaust m 0.4	m 0.4
				<b>Exhaust m 1.0</b>		m 0.5
Complete intake terminal Ø80, 1 m		Intake 3	m 0.5	<b>Intake m 3.4</b>	Exhaust m 0.9	m 1.4
Intake terminal Ø 80 Exhaust terminal Ø 80		Intake 2.2 Exhaust 1.9	m 0.35 m 0.3	<b>Intake m 2.5</b>	Exhaust m 0.6	m 1
				<b>Exhaust m 1.6</b>		m 0.9
Bend 90° Ø80		Intake 1.9 Exhaust 2.6	m 0.3 m 0.4	<b>Intake m 2.2</b>	Exhaust m 0.8	m 0.9
				<b>Exhaust m 2.1</b>		m 1.2
Bend 45° Ø80		Intake 1.2 Exhaust 1.6	m 0.2 m 0.25	<b>Intake m 1.4</b>	Exhaust m 0.5	m 0.5
				<b>Exhaust m 1.3</b>		0.7
Pipe Ø 60 m 1 for ducting		Exhaust 3.3	m 0.5	Intake 3.8	<b>Exhaust m 1.0</b>	m 1.5
				Exhaust 2.7		
Bend 90° Ø60 for ducting		Exhaust 3.5	m 0.55	Intake 4.0	<b>Exhaust m 1.1</b>	m 1.6
				Exhaust 2.9		
Reduction Ø 80/60		Intake and Exhaust 2.6	m 0.4	Intake m 3.0	<b>Exhaust m 0.8</b>	m 1.2
				Exhaust m 2.1		
Terminal complete with exhaust vertical Ø60 for ducting		Exhaust 12.2	m 1.9	Intake m 14	<b>Exhaust m 3.7</b>	m 5.8
				Exhaust m 10.1		

### 1.9 OUTDOOR INSTALLATION IN PARTIALLY PROTECTED AREA.

**N.B.:** a partially protected area is one in which the appliance is not exposed to the direct action of the weather (rain, snow, hail, etc...).

• **Configuration type B, open chamber and forced draught.**

Using the relevant cover kit direct air intake is possible (Fig. 1-9) and combustion products are exhausted into a single flue or directly to the outside. In this configuration it is possible to install the boiler in a partially protected place. In this configuration the boiler is classified as type B<sub>23</sub>.

With this configuration:

- air intake takes place directly from the environment in which the appliance is installed (external);
- the flue exhaust must be connected to its own individual flue or channelled directly into the external atmosphere.

The technical regulations in force must be respected.

- **Kit assembly (Fig. 1-11):** Remove the two plugs and the gaskets present from the two lateral holes with respect to the central one. Now cover the right intake hole using the relevant plate, fixing it onto the left side using the two previously-removed screws. Install the Ø80 outlet flange on the central hole of the boiler, taking care to insert the gasket supplied with the kit and tighten by means of the screws provided. Install the upper cover, fixing it using the 4 screws present in the kit, positioning the relevant gaskets. Engage the 90° Ø80 bend with the male side (smooth) in the female side (with lip seal) of the Ø80 flange until it stops. Introduce the gasket, making it run along the bend. Fix it using the sheet steel plate and tighten by means of the straps present in the kit, making sure to block the 4 gasket flaps. Fit the male side (smooth) of the exhaust terminal into the the female side of the bend 90° Ø80, making sure that the relevant wall sealing plate is already fitted; this will ensure the hold and joining of the elements making up the kit.

**Max. length of exhaust duct.** The flue pipe (vertical or horizontal) can be extended to a max. length of 30 straight metres.

- **Coupling of extension pipes.** To install push-fitting extensions with other elements of the flue, proceed as follows: Couple the pipe or elbow with the male side (smooth) in the female side (with lip seal) to the end stop on the previously installed element. This will ensure sealing efficiency of the coupling.

**Example of installation with direct vertical terminal in partially protected location.** When the vertical terminal for direct discharge of combustion products is used, a minimum gap of 300 mm must be left between the terminal and the balcony above. The height X+Y+Z+W evaluated with respect to the balcony above, must be equal to or more than 2000 mm. (Fig. 1-10). The term W must only be considered if the balcony above has closed balustrade (W=0 if the balustrade is open).

• **Configuration without cover kit in a partially protected location (type C boiler)**

By leaving the side plugs fitted it is possible to install the appliance externally without the cover kit. Installation takes place using the Ø60/100 and Ø80/125 concentric intake/exhaust and separator Ø80/80 kits. Refer to the paragraph relative to indoor installation. In this configuration the upper cover kit guarantees additional protection for the boiler. It is recommended but not compulsory.

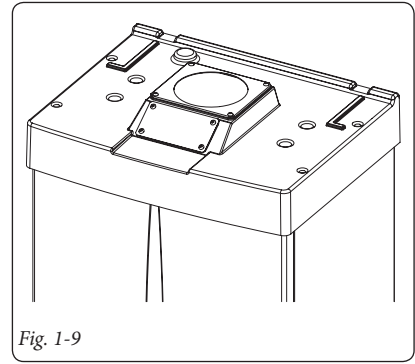

Fig. 1-9

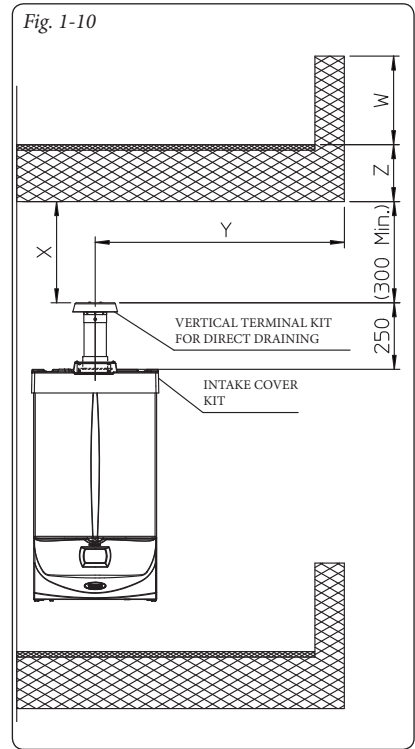

Fig. 1-10

INSTALLER

USER

MAINTENANCE TECHNICIAN

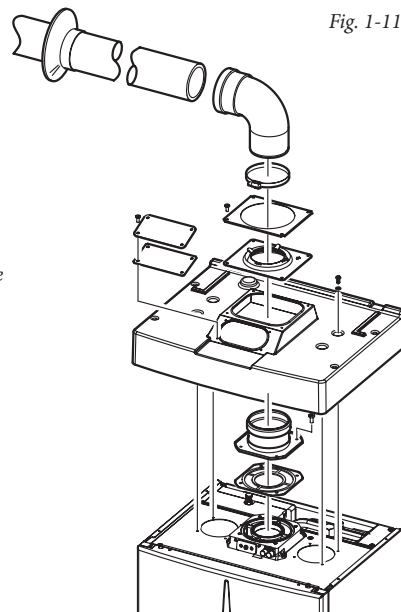

Fig. 1-11

The cover kit includes:

- N° 1 Heat moulded cover
- N° 1 Gasket clamping plate
- N° 1 Gasket
- N° 1 Gasket clamp
- N° 1 Intake hole covering plate

The terminal kit includes:

- N° 1 Gasket
- N° 1 Exhaust flange Ø80
- N° 1 Bend 90° Ø80
- N° 1 Exhaust pipe Ø80
- N° 1 Wall sealing plate

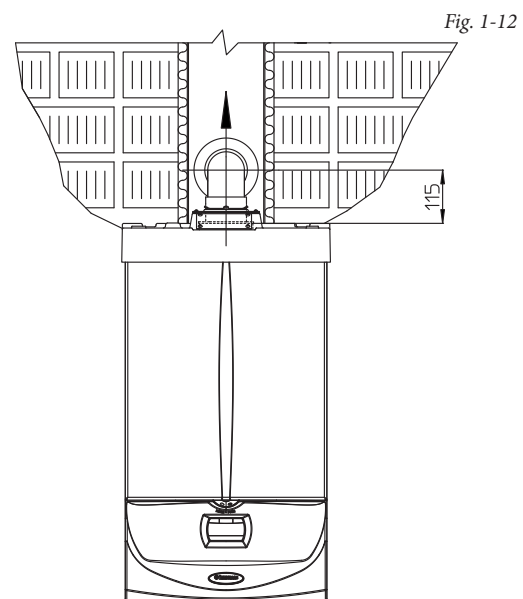

Fig. 1-12

**1.10 HORIZONTAL CONCENTRIC KIT INSTALLATION.**

**Type C configuration, sealed chamber and fan assisted.**

**Horizontal intake - exhaust kit Ø60/100.** Kit assembly (Fig. 1-13): install the bend with flange (2) on the central hole of the boiler, positioning the gasket (1) (*which does not require lubrication*) positioning it with the circular projections downwards in contact with the boiler flange and tighten using the screws present in the kit. Engage the bend (3) with the male side (smooth) until it is fully home on the adapter (1). Fit the Ø60/100 (3) concentric terminal pipe with the male end (smooth) to the female end of the bend (2) up to the stop; making sure that the internal and external wall sealing plate have been fitted, this will ensure sealing and joining of the elements making up the kit.

- Extensions for horizontal kit Ø60/100 (Fig. 1-14). The kit with this configuration can be extended up to a *max. horizontal distance of 12.9 m* including the terminal with grid and excluding the concentric bend leaving the boiler. This configuration corresponds to a resistance factor of 100. In these cases the special extensions must be requested.

**Horizontal intake - exhaust kit Ø80/125.** Kit assembly (Fig. 1-15): for the installation of kit Ø80/125 the flanged adapter kit must be used to be able to install the flue system Ø80/125. Install the flanged adapter (2) on the central hole of the boiler, positioning the gasket (1) (*which does not require lubrication*) with the circular projections downwards in contact with the boiler flange and tighten using the screws present in the kit. Engage the bend (3) with the male side (smooth) until it is fully home on the adapter (1). Fit the Ø80/125 (5) concentric terminal pipe with the male end (smooth) to the female end of the bend (4) (with lip seal) up to the stop; making sure that the internal (6) and external wall sealing plates (7) have been fitted, this will ensure sealing and joining of the elements making up the kit.

- Extensions for horizontal kit Ø80/125 (Fig. 1-16). The kit with this configuration can be extended up to a *max. distance of 32 m* including the terminal with grid and excluding the concentric bend leaving the boiler. If additional components are assembled, the length equivalent to the maximum allowed must be subtracted. In this case the special extensions must be requested.
- External grid. **N.B.:** for correct functioning of the system the terminal with grid must be installed correctly ensuring that, the "high" indication present on the terminal is respected on installation.

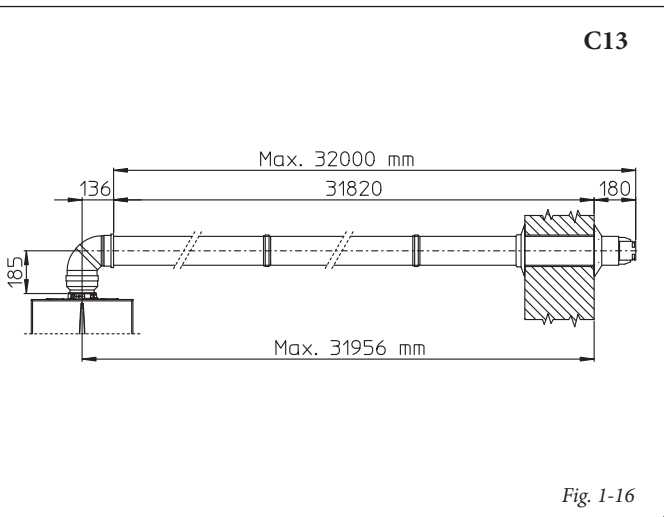
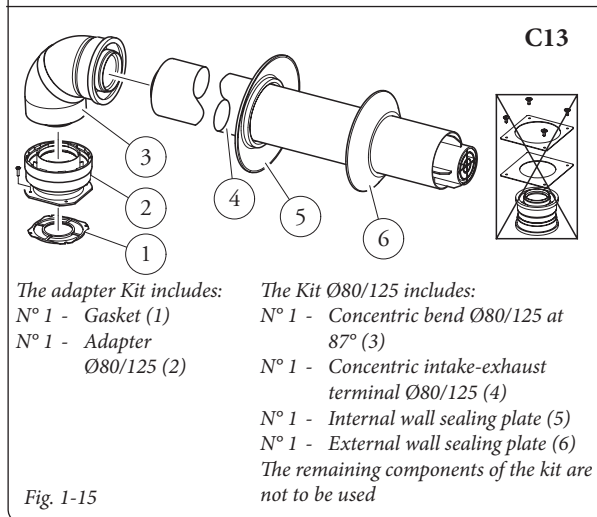
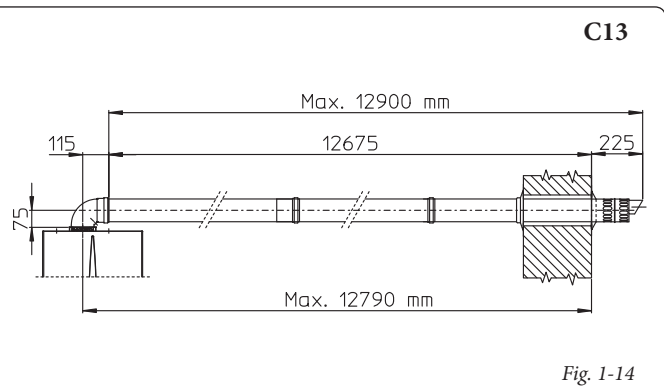
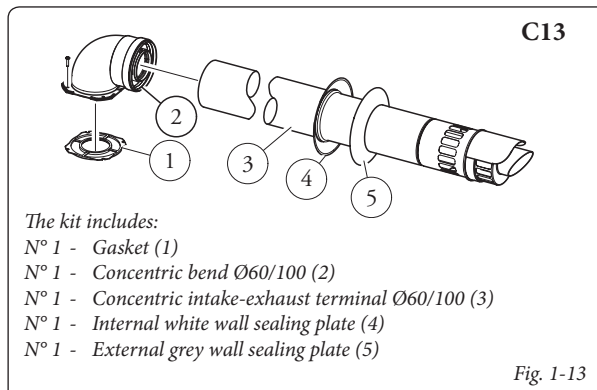

**1.11 VERTICAL CONCENTRIC KIT INSTALLATION.**

**Type C configuration, sealed chamber and fan assisted.**

Vertical concentric of intake and exhaust kit. This terminal enables the air intake and the flue exhausts to be directly emitted outside the house in a vertical direction.

**N.B.:** the vertical kit with aluminium tile enables installation on terraces and roofs with a maximum slope of 45% (approximately 25°) and the height between the terminal cap and half-shell (374 mm for Ø60/100 and 260 mm for Ø80/125) must always be respected.

**Vertical kit with aluminium tile Ø60/100.**

Kit assembly (Fig. 1-17): install the concentric flange (2) on the central hole of the boiler, positioning the gasket (1) (*which does not require lubrication*) with the circular projections downwards in contact with the boiler flange and tighten using the screws present in the kit. Imitation aluminium tile installation: replace the

tile with the aluminium sheet (4), shaping it to ensure that rainwater runs off. Position the fixed half-shell (6) and insert the intake-exhaust pipe (5). Fit the Ø60/100 (3) concentric terminal pipe with the male end (5) (smooth) into the flange (2) up to the stop; making sure that the wall sealing plate has been fitted (3), this will ensure sealing and joining of the elements making up the kit.

- Extensions for vertical kit Ø60/100 (Fig. 1-18). The vertical kit with this configuration can be extended to a *max. straight vertical length of 14.4 m* including the terminal. This configuration corresponds to a resistance factor of 100. In this case the special extensions must be requested.

**Vertical kit with aluminium tile Ø80/125.**

Kit assembly (Fig. 1-19): for the installation of kit Ø80/125 the flanged adapter kit must be used to be able to install the flue system Ø80/125. Install the flanged adapter (2) on the central hole of the boiler, positioning the gasket (1) (*which does not require lubrication*) with the circular projections downwards in contact with the boiler flange

and tighten using the screws preset in the kit. Imitation aluminium tile installation: replace the tile with the aluminium sheet (4), shaping it to ensure that rainwater runs off. Position the fixed half-shell (5) on the aluminium tile and insert the intake-exhaust pipe (7). Fit the Ø80/125 concentric terminal pipe with the male end (smooth) to the female end of the adapter (1) (with lip gasket) up to the stop; making sure that the wall sealing plate has been fitted (3), this will ensure sealing and joining of the elements making up the kit.

- Extensions for vertical kit Ø80/125 (Fig. 1-20). The vertical kit with this configuration can be extended to a *max. length of 32 m* including the terminal. If additional components are assembled, the length equivalent to the maximum allowed must be subtracted. In this case specific extensions must be requested.

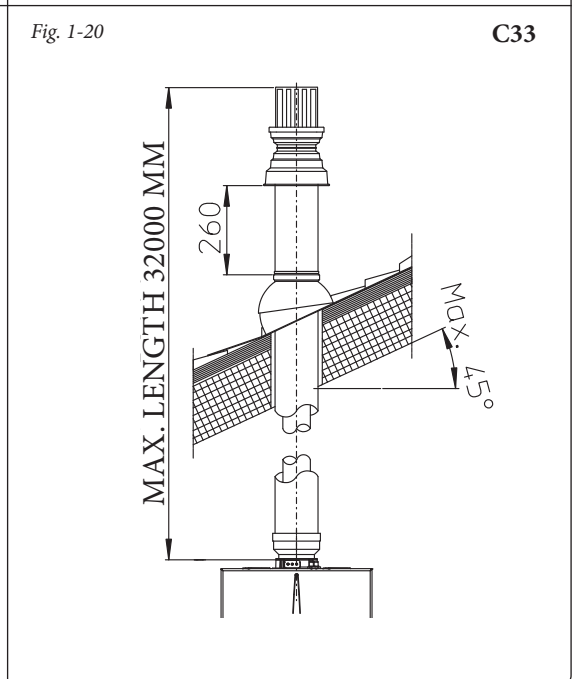
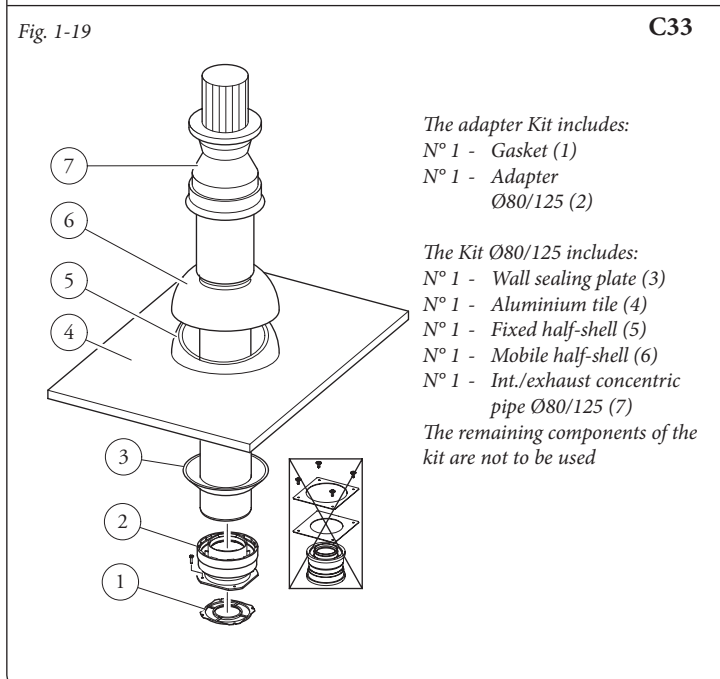
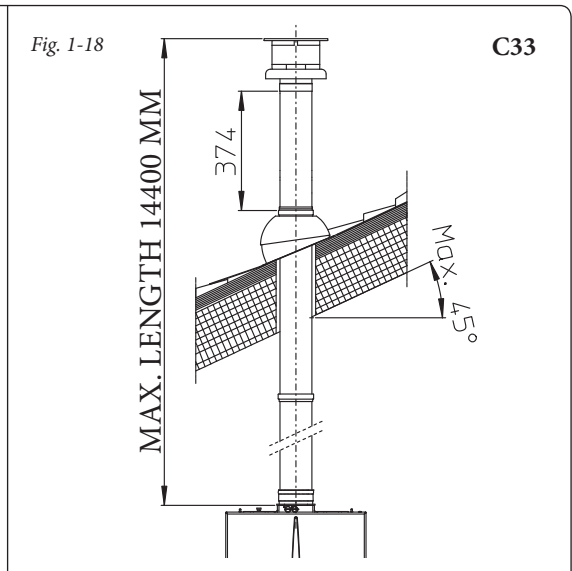
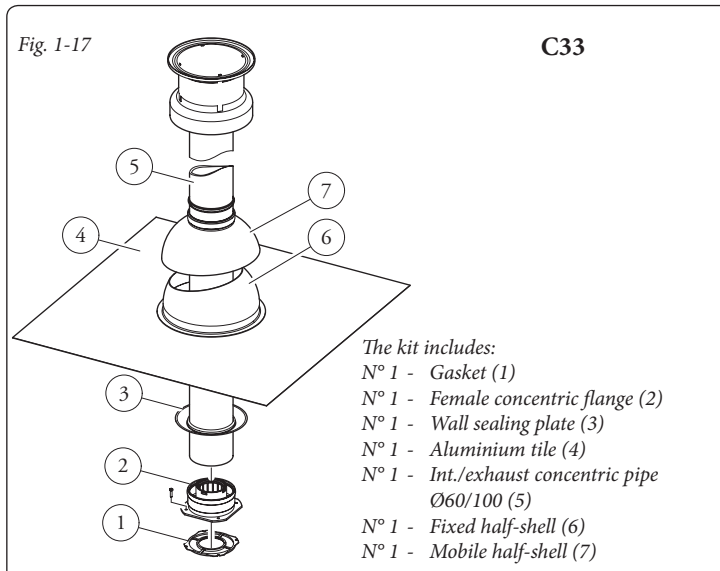

**1.12 SEPARATOR KIT INSTALLATION.**  
**Type C configuration, sealed chamber and fan assisted.**

**Separator kit Ø80/80.** This kit allows the air intake from outside the home and the flue exhaust into a chimney or flue by means of the separation of the flue exhaust pipes and air intake. Combustion products are expelled from pipe (S) (in plastic, so as to resist acid condensate). Air is taken in through duct (A) for combustion (this is also in plastic). The intake pipe (A) can be installed either on the right or left hand side of the central exhaust pipe (S). Both ducts can be routed in any direction.

- Kit assembly (Fig. 1-21): install the flange (4) on the central hole of the boiler, positioning the gasket (1) (*which does not require lubrication*). Position it with the circular projections downwards in contact with the boiler flange and tighten using the hex screws with flat end present in the kit. Remove the flat flange present in the lateral hole with respect to the central one (according to needs) and replace it with the flange (3), positioning the gasket (2) already present in the boiler and tighten using the supplied self-threading screws. Fit the male end (smooth) to the bends (5) in the female end of the flanges (3 and 4). Fit the intake terminal (6) with the male section (smooth) in the female section of the bend (5) up to the stop, ensuring that the internal and external wall sealing plates are fitted. Fit the exhaust pipe (9) with the male end (smooth) to the female

end of the bend (5) up to the stop; making sure that the internal wall sealing plate has been fitted, this will ensure sealing and joining of the elements making up the kit.

- Installation clearance (Fig. 1-22). The minimum installation clearance measurements of the Ø80/80 separator terminal kit have been stated in some limit conditions.
- Extensions for Ø80/80 separator kit. The maximum vertical straight length (without bends) that can be used for Ø80 intake and exhaust pipes is 41 metres, independently to whether they are used for intake or exhaust. The maximum horizontal straight length (with bend in suction and in exhaust) that can be used for Ø80 intake and exhaust pipes is 36 metres independently to whether they are used for intake or exhaust.

**N.B.:** to favour the removal of possible condensate forming in the exhaust pipe, tilt the pipes towards the boilers with a min. slope of 1.5%. (Fig. 1-23).

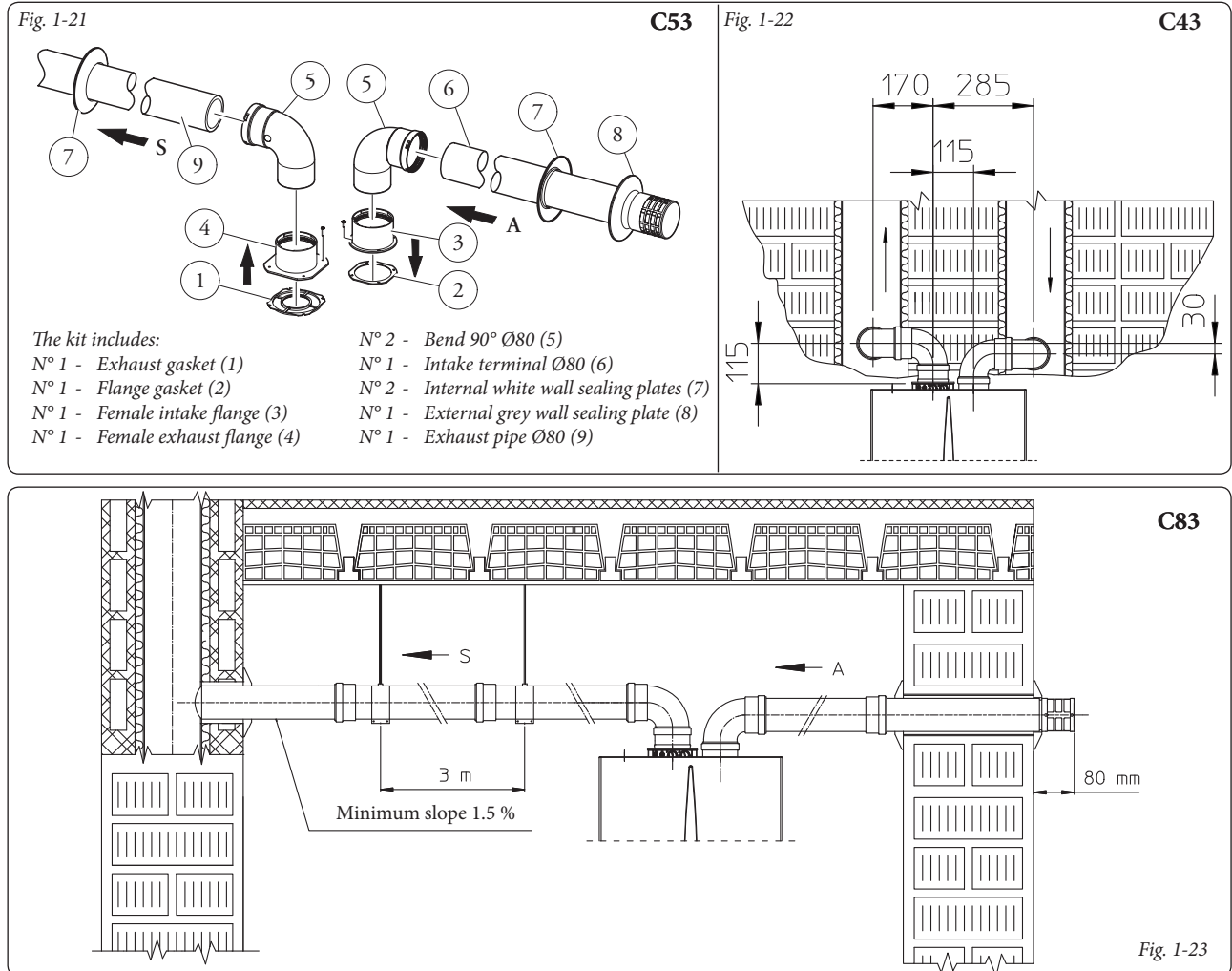

**1.13 ADAPTER KIT INSTALLATION C9.**

The current kit allows for the installation of one Immergas boiler in configuration "C93", carrying out the combustion air intake directly from the air shaft where the flue exhausts are carried out by means of a ducting system.

**System composition.**

The kit must be combined with the following components (sold separately) to be functional and complete:

- kit C93 version Ø100 or Ø125
- ducting kit Ø60 or Ø80
- flue exhaust kit Ø60/100 o Ø80/125 configuration based on the installation and the type of boiler.

**Kit assembly.**

- Assemble the components of kit "C9" on door (A) of the ducting system (Fig. 1-25).
- (Only version Ø125) install the adapter flange (11) positioning the concentric gasket (10) on the boiler and tighten using the screws in the kit (12).
- Carry out the ducting system assembly as described in the relative instructions sheet.
- Calculate the distance between the boiler exhaust and the ducting system bend.
- Prepare the boiler flue by calculating that the internal pipe of the concentric kit must engage until the end stop in the ducting system bend (quota "X" fig. 1-26).

**N.B.:** to favour the removal of possible condensate forming in the exhaust pipe, tilt the pipes towards the boiler with a min. slope of 1.5%.

- Assemble the lid (A) complete with adapter (1) and wall plugs (6) and assemble the flue to the ducting system.

**N.B.:** (only version Ø125) before assembling check that the positioning of the gaskets is correct. In the case the components lubrication (already carried out by the manufacturer) is not sufficient, remove the residual lubricant using a dry cloth, then to ease fitting spread the elements with common or industrial talc.

Once all the components are assembled correctly the flue exhausts will be expelled by the ducting systems, for the normal operation of the boiler the combustion air will take in the air directly from the air shaft (Fig. 1-26).

**Technical data.**

- The dimensions of the air shafts must guarantee an minimum gap between the external wall of the flue pipe and the internal wall of the air shaft: 30 mm per circular section air shafts and 20 mm in the case of squared section air shaft (Fig. 1-24).
- On the vertical section of the flue a maximum of 2 changes of direction with a maximum angle of incidence of 30° with respect to the vertical.
- The maximum vertical extension using a ducting system of Ø60 is 13 m, the maximum extension includes 1 bend Ø60/10 at 90°, 1 m of pipe 60/100 in horizontal, 1 bend 90° Ø60 ducted and the roof terminal for ducting.

For the determination of the flue system C93 in different configurations than those previously described (Fig. 1-26) it is necessary to consider that 1 metre of ducted pipe according to the

indications described, has a resistance factor equal to 4.9.

- The maximum vertical extension using a ducting system of Ø80 is 28 m, the maximum extension includes 1 adapter from 60/100 to 80/125, 1 m bend Ø80/125 to 87°, 1 m of pipe 80/125 in horizontal, 1 bend 90° Ø80 ducted and the roof terminal for ducting.

For the determination of the flue system C93 in different configurations than those previously described (Fig. 1-26) it is necessary to consider the following head loss:

- 1 m of pipe Ø1 m concentric duct Ø80/125 = 1 m of ducted pipe;
- 1 bend at 87° = 1.4 m of dusted pipe.

As a consequence it is necessary to subtract the equivalent length of the added part to the 28 m available.

Fig. 1-24

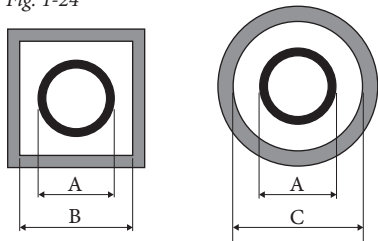

Rigid Ø60 Ducting (A) mm	AIR SHAFT (B) mm	AIR SHAFT (C) mm
66	106	126

Rigid Ø80 Ducting (A) mm	AIR SHAFT (B) mm	AIR SHAFT (C) mm
86	126	146

Flexible Ø80 Ducting (A) mm	AIR SHAFT (B) mm	AIR SHAFT (C) mm
90	130	150

**Kit composition:**

Ref.	Qty	Description
1	1	Door adapter Ø100 or Ø125
2	1	Door gasket in neoprene
3	4	Screws 4.2 x 9 AF
4	1	Screw TE M6 x 20
5	1	Flat washer in nylon M6
6	2	Door hole closure steel cap
7	1	Neoprene cap gasket
8	1	Toothed washer M6
9	1	Nut M6
10	1 (kit 80/125)	Concentric gasket Ø60/-100
11	1 (kit 80/125)	Flanged adapter Ø80/-125
12	4 (kit 80/125)	Screws TE M4 x 16 flat head screwdriver
-	1 (kit 80/125)	Lubricant talc bag

**Supplied separately:**

Ref.	Qty	Description
A	1	Ducting kit door

**Installation drawings key:**

- ① Unmistakeable component identification present in the kit
- A Identification component not supplied with this kit

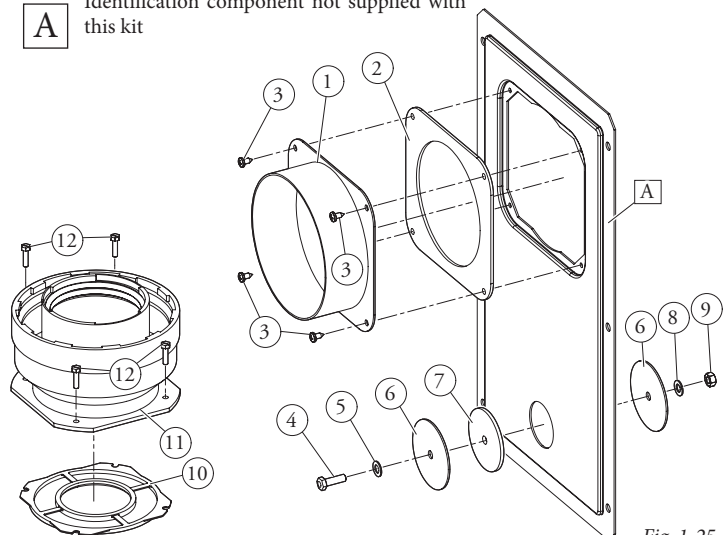

Fig. 1-25

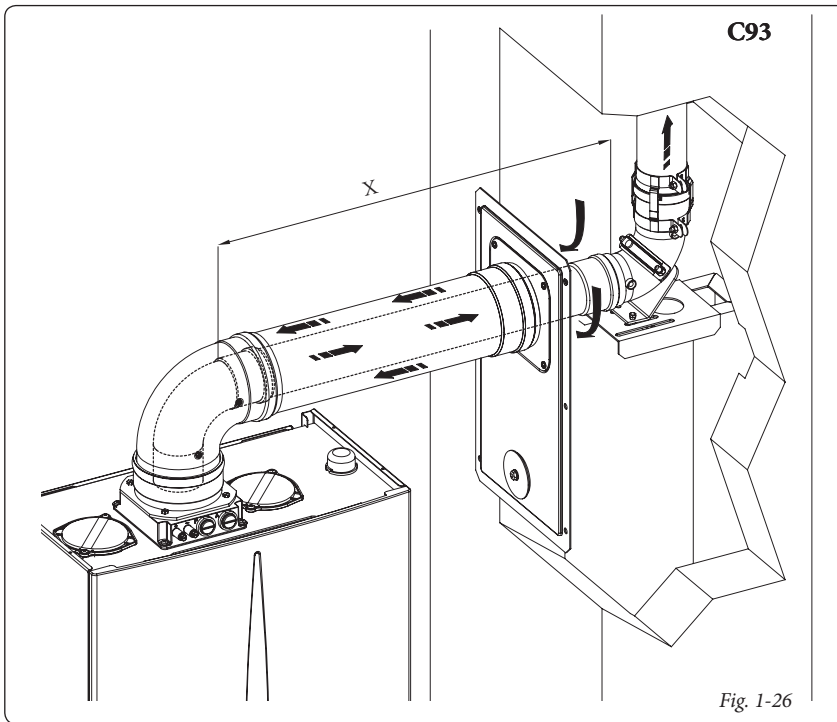

Fig. 1-26

#### 1.14 DUCTING OF FLUES OR TECHNICAL SLOTS.

Ducting is an operation through which by the introduction of one or more relevant pipes, a system is realised for the evacuation of the combustion products of a gas appliance made up from the coupling of an existing or new ducting pipe with a chimney, flue or technical slot (also in new buildings) (Fig. 1-27). Ducting requires the use of ducts declared to be suitable for the purpose by the manufacturer, following the installation and user instructions, provided by the manufacturer and the requirements of the standards.

**Immergas ducting system.** *The Ø60 rigid and Ø80 flexible "Green Range" ducting systems must only be used for domestic use and with Immergas condensing boilers.*

In any case, ducting operations must respect the provisions contained in the standard and in current technical regulations; in particular, the declaration of conformity must be compiled at the end of work and on commissioning of the ducted system. The instructions in the project or technical report must likewise be followed, in cases provided for by the standard and current technical regulations. The system or components of the system have a technical life complying with current standards, provided that:

- it is used in average atmospheric and environmental conditions, according to current regulations (absence of combustion products, dusts or gases that can alter the normal thermophysical or chemical conditions; existence of temperatures coming within the standard range of daily variation, etc.).
- Installation and maintenance must be performed according to the indications supplied by the manufacturer and in compliance with the provisions in force.

- The max. possible length of the Ø60 flexible ducting vertical section is equal to 22 m. This length is obtained considering the complete Ø80 exhaust terminal, 1m of Ø80 pipe in exhaust, two 90° Ø80 bends at boiler outlet.
- The max. possible length of the Ø80 flexible ducting vertical section is equal to 30 m. This length is obtained considering the complete exhaust terminal, 1m of Ø80 pipe in exhaust, two 90° Ø80 bends at boiler outlet for connecting to the ducting system and two direction changes of the flexible tube inside the flue/technical slot.
- The max. possible length of the Ø60 flexible ducting vertical section is equal to 30 m. This length is obtained considering the complete Ø80 exhaust terminal, 1m of Ø80 pipe in exhaust, two 90° Ø80 bends at boiler outlet.

#### 1.15 CONFIGURATION TYPE B<sub>23</sub> OPEN CHAMBER AND FORCED DRAUGHT FOR INSIDE.

The appliance can be installed inside buildings in B<sub>23</sub> mode; in this eventuality, all technical rules and national and local regulations in force, must be complied with.

- Type B open chamber boilers must not be installed in places where commercial, artisan or industrial activities take place, which use products that may develop volatile vapours or substances (e.g. acid vapours, glues, paints, solvents, combustibles, etc.), as well as dusts (e.g. dust deriving from the working of wood, coal fines, cement, etc.), which may be damaging for the components of the appliance and jeopardise functioning.
- In type B<sub>23</sub> configuration, the boilers must not be installed in bedrooms, bathrooms or in bedsitters.

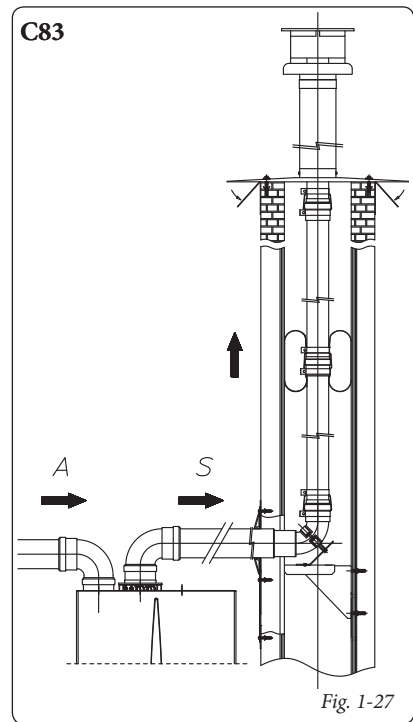

Fig. 1-27

- The installation of appliances in B<sub>23</sub> configuration is only recommended outdoors (in a partially protected place) or in places that are not lived in and which are permanently ventilated.

For the installation it is necessary to use the cover kit found in paragraph 1.9.

#### 1.16 FLUE EXHAUST TO FLUE/CHIMNEY.

Flue exhaust does not necessarily have to be connected to a branched type traditional flue. The flue exhaust, for boiler clots installed in C configuration, can be connected to a special LAS type multiple flue. For B<sub>23</sub> configurations, exhaust is only allowed into individual flue or directly into the external atmosphere via a relevant terminal. The multiple flues and the combined flues must also only be connected to type C appliances of the same type (condensing), having nominal heat inputs that do not differ by more than 30% less with respect to the maximum that can be attached and powered by the same fuel. The thermo-fluid dynamic features (flue flow rate, % of carbon dioxide, % humidity etc...) of the appliances attached to the same multiple flues or combined flues, must not differ by more than 10% with respect to the average boiler attached. Multiple and combined flues must be specially designed according to the calculation method and requirements of the standards, by professionally qualified technical staff. Chimney or flue sections for connection of the exhaust pipe must comply with requisites of technical standards in force.

### 1.17 FLUES, CHIMNEYS, CHIMNEY CAPS AND TERMINALS.

The flues, chimneys and chimney caps for the evacuation of combustion products must be in compliance with standards in force. The chimney caps and the roof exhaust terminals must respect the outlet quotas and the distance of the foreseen technical volumes from the current technical regulations.

**Positioning the wall exhaust terminals.** The exhaust terminals must:

- be installed on external perimeter walls of the building;
- be positioned according to the minimum distances specified in current technical standards.

**Combustion products exhaust of natural or fan assisted appliances in open-top closed environments.** In spaces closed on all sides with open tops (ventilation pits, air shafts, courtyards etc.), direct flue exhaust is allowed for conventional or fan assisted draught gas appliances with a heating power range from 4 to 35 kW, provided the conditions as per the current technical standards are respected.

### 1.18 SYSTEM FILLING.

Once the boiler is connected, proceed with system filling via the filling valve (Fig. 1-29 and 2-8). Filling is performed at low speed to ensure release of air bubbles in the water via the boiler and heating system vents.

The boiler has a built-in automatic venting valve on the circulator. *Check if the cap is loose.* Open the radiator air vent valves.

Close radiator vent valves when only water escapes from them.

Close the filling valve when the boiler manometer indicates approx. 1.2 bar.

**N.B.:** during these operations start/up the circulation pump at intervals, acting on the main switch positioned on the control panel. *Vent the circulation pump by loosening the front cap and keeping the motor running.* Re-tighten the cap after the operation.

### 1.19 FILLING THE CONDENSATE TRAP.

On first lighting of the boiler combustion products may come out the condensate drain; after a few minutes' operation check that this no longer occurs. This means that the trap is filled with condensate to the correct level preventing the passage of combustion products.

### 1.20 GAS SYSTEM START-UP.

To start up the system, refer to the current regulations. This divides the systems and therefore the start-up operations into three categories: new systems, modified systems, re-activated systems.

In particular, for new gas systems:

- open windows and doors;
- avoid presence of sparks or naked flames;
- bleed all air from pipelines;
- check that the internal system is properly sealed according to specifications.

### 1.21 BOILER START UP (IGNITION).

For issue of the Declaration of Conformity provided for by Italian Law, the following must be performed for boiler start-up:

- check that the internal system is properly sealed according to specifications;
- ensure that the type of gas used corresponds to boiler settings;
- switch the boiler on and ensure correct ignition;
- make sure that the gas flow rate and relevant pressure values comply with those given in the manual ( Par. 3.18);
- ensure that the safety device is engaged in the event of gas supply failure and check activation time;
- check activation of the main switch located upstream from the boiler and in the boiler;
- check that the concentric intake-exhaust terminal (if fitted) is not blocked.

The boiler must not be started up even if only one of the checks should be negative.

**N.B.:** *the boiler preliminary check must be carried out by a qualified technician. The boiler warranty is valid as of the date of testing.*

*The test certificate and warranty is issued to the user.*

**1.22 CIRCULATION PUMP.**

The boilers are supplied with a built-in circulation pump with variable speed. When the boiler is in heating phase the speed of the pump is defined according to the "P57" in the configuration menu (Parag. 3.8), in sanitary phase the pump functions at maximum speed.

In heating phase the Auto and Fixed mode operations are available.

- **Auto:** automatic pump speed. In this mode it is possible to choose between the options at "Proportional prevalence" and "ΔT constant".
  - **Proportional prevalence (ΔT = 0):** the pump speed varies based on the power supplied by the burner, greater the power, greater the speed. Moreover, inside the parameter it is possible to regulate the operation range of the pump by setting the maximum speed (adjustable from 100 % ÷ 55 %) and the minimum speed (adjustable from 55 % to the max set speed).
  - **ΔT Constant (ΔT = 5 ÷ 25 K):** at variable pump speed to keep the ΔT constant between system flow and return depending on the set value of K. Moreover, inside the parameter it is possible to regulate the operation range of the pump by setting the maximum speed (adjustable from 100 % ÷ 55 %) and the minimum speed (adjustable from 54 % to the max set speed).
- **Fixed (100 % ÷ 55 %):** in this mode the pump operates at a constant speed, the range of work is defined between the minimum (55 %) and the maximum (100 %).

**Pump release.** If, after a prolonged period of inactivity, the circulation pump is blocked, unscrew the front cap and turn the motor shaft using a screwdriver. Take great care during this operation to avoid damage to the motor.

Head available to the system.

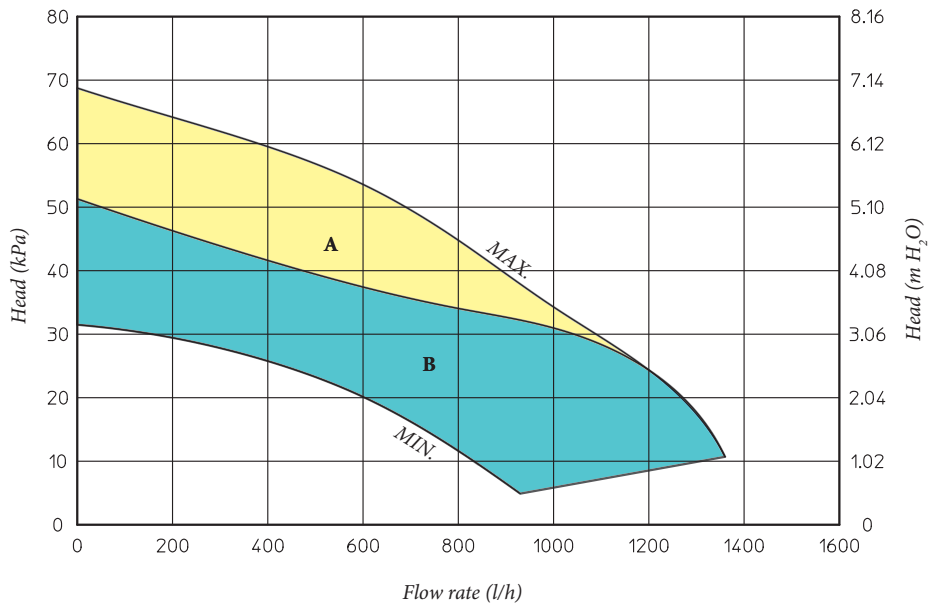

Key:  
 A+B = Head available with by-pass excluded (closed) in Auto mode  
 B = Head available with by-pass inserted (open) in Auto mode

Fig. 1-28

**1.23 KITS AVAILABLE ON REQUEST.**

- System cut-off valve kits with or without inspectionable filter (on request). The boiler is designed for installation of system interception cocks to be placed on flow and return pipes of the connection assembly. This kit is very useful for maintenance because it allows to empty just the boiler without having to empty the entire system. Moreover, the version with filter preserves the functioning characteristics of the boiler thanks to its inspectionable filter.

- System zone control unit kit (on request). If the central heating system is to be divided into several zones (**max. three**) in order to interlock them with separate adjustments and to keep water flow rate high for each zone, Immergas supplies zone system kits on request.
- Polyphosphate dispenser kit (on request). The polyphosphate dispenser reduces the formation of lime-scale and preserves the original heat exchange and domestic hot water production conditions. The boiler is prepared for application of the polyphosphate dispenser kit.

- Relay board (on request). The boiler is prepared for the installation of a relay card that allows to increase the features of the appliance and therefore functioning possibilities.
- Cover kit (on request). If installed outdoors in a partially protected place with direct air intake, it is compulsory to mount the appropriate top protection cover for the correct functioning of the boiler and to protect it from adverse weather conditions.

The above-mentioned kits are supplied complete with instructions for assembly and use.

**1.24 BOILER COMPONENTS.**

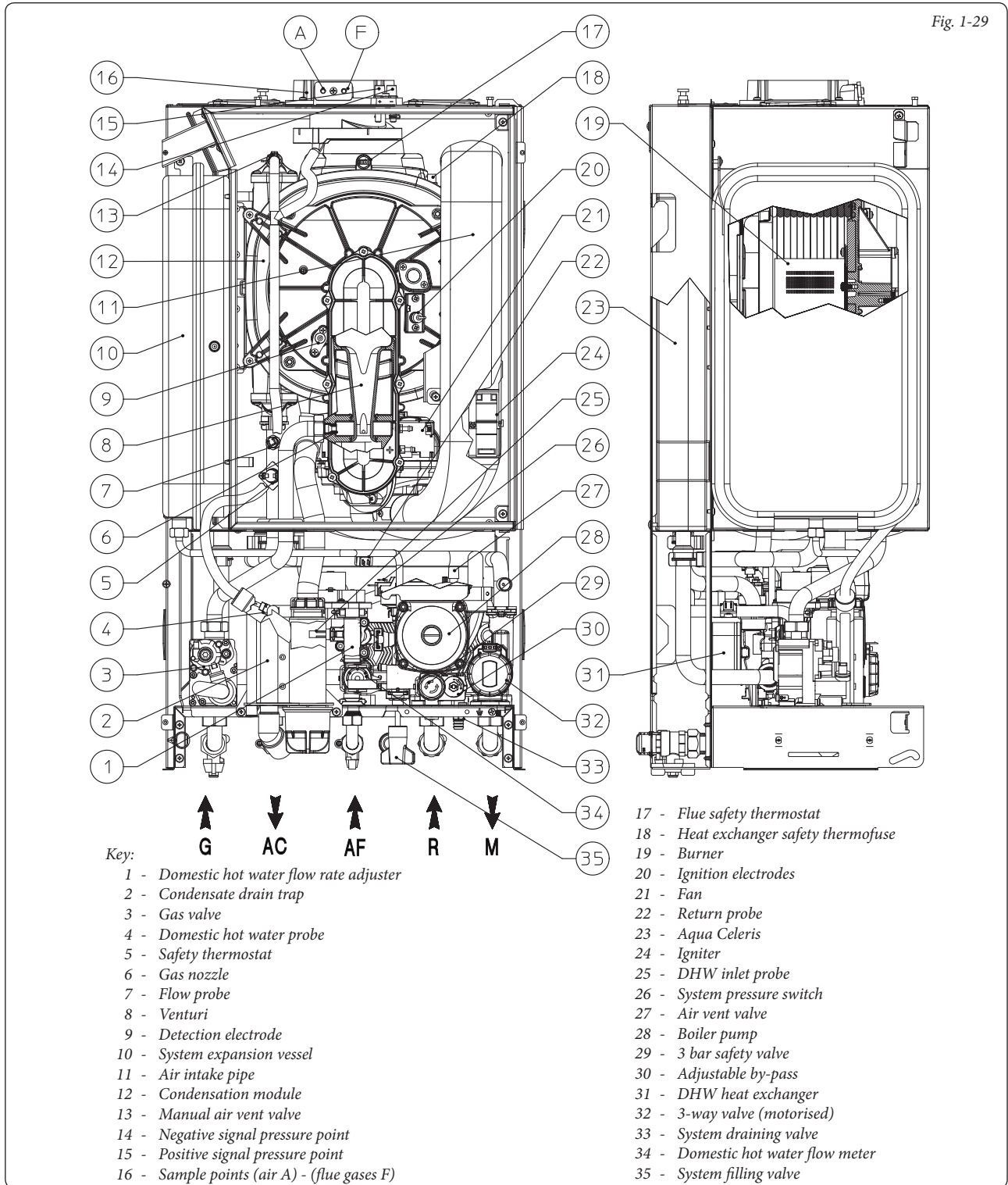

## 2 INSTRUCTIONS FOR USE AND MAINTENANCE.

### 2.1 CLEANING AND MAINTENANCE.

**Attention:** the heating systems must undergo periodical maintenance (regarding this, see the section dedicated to the maintenance technician, relative to “yearly control and maintenance of the appliance”) and regular checks of energy efficiency in compliance with national, regional or local provisions in force.

This ensures that the optimal safety, performance and operation characteristics of the boiler remain unchanged over time.

We recommend stipulating a yearly cleaning and maintenance contract with your zone technician.

### 2.2 GENERAL WARNINGS.

Never expose the wall-mounted boiler to direct vapours from a cooking surface.

Use of the boiler by unskilled persons or children is strictly prohibited.

For safety purposes, check that the concentric air intake/flue exhaust terminal (if fitted), is not blocked.

If temporary shutdown of the boiler is required, proceed as follows:

- a) drain the heating system if anti-freeze is not used;

b) shut-off all electrical, water and gas supplies.

In the case of work or maintenance to structures located in the vicinity of ducting or devices for flue extraction and relative accessories, switch off the appliance and on completion of operations ensure that a qualified technician checks efficiency of the ducting or other devices. Never clean the appliance or connected parts with easily flammable substances.

Never leave containers or flammable substances in the same environment as the appliance.

• **Attention:** the use of components involving use of electrical power requires some fundamental rules to be observed:

- do not touch the appliance with wet or moist parts of the body; do not touch when barefoot;
- never pull electrical cables or leave the appliance exposed to atmospheric agents (rain, sunlight, etc.);
- the appliance power cable must not be replaced by the user;
- in the event of damage to the cable, switch off the appliance and contact exclusively qualified staff for replacement;
- if the appliance is not to be used for a certain period, disconnect the main power switch.

**N.B.:** the temperatures indicated by the display have a tolerance of +/- 3°C due to environmental conditions that cannot be blamed on the boiler.

### 2.3 CONTROL PANEL.

Key:

- ⏻ - Stand-by - On Button
- A - Summer (☀️) and winter (❄️) functioning mode selection button
- B - Aqua Celeris Activation Button (🔧)
- C - (RESET) / menu exit (ESC) reset button
- D - Menu entry button (MENU) / data confirmation (OK)
- 1 - Domestic hot water temperature selector
- 2 - Domestic hot water temperature set
- 3 - Heating temperature selector

- 4 - Central heating temperature set
- 5 - Anomaly present
- 6 - Display of boiler functioning status
- 8 - Flame presence symbol and relative output scale
- 9 and 7 - Primary heat exchanger output water temperature
- 10 - Boiler in stand-by
- 11 - Boiler connected to remote control (Optional)
- 12 - Operation in summer mode
- 13 - Anti-freeze function in progress.
- 14 - Operation in winter mode
- 15 - Functioning with Aqua Celeris active
- 16 - Connection to external tools for technician
- 17 - Display of menu items
- 18 - Functioning with external temperature probe active
- 19 - Display of data confirmation or menu access
- 20 and 7 - External temperature display with external probe connected (optional)
- 21 - Display of reset or exit menu request
- 22 - Chimney sweep function in progress
- 23 - Boiler manometer
- 24 - Multifunction display

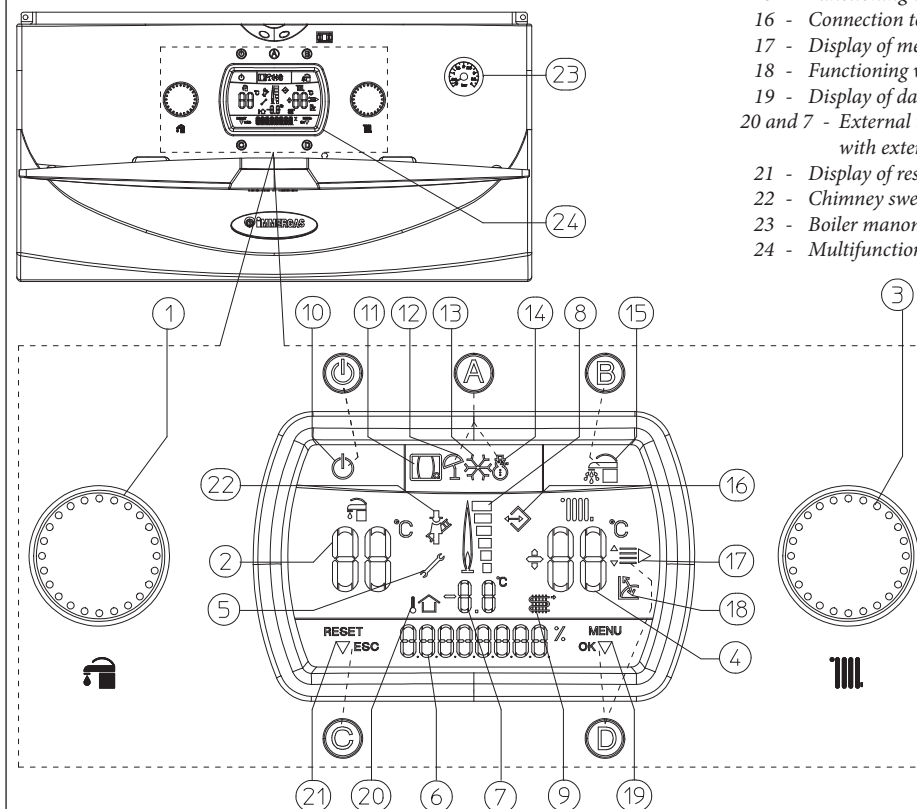

Fig. 2-1

## 2.4 DESCRIPTION OF FUNCTIONING STATES.

Below find a list of boiler functioning states that appear on the multifunction display (24) by means of the indicator (6) with a brief description. Refer to the instruction book for a complete explanation.

Display (6)	Description of functioning states
<b>SUMMER</b>	Summer functioning mode without request in progress. Boiler in stand-by for domestic hot water request.
<b>WINTER</b>	Winter functioning mode without request in progress. Boiler in stand-by for domestic hot water or central heating request.
<b>DHW ON</b>	Domestic hot water mode in progress. Boiler functioning, domestic hot water heating in progress.
<b>CH ON</b>	Central heating mode in progress. Boiler functioning, central heating in progress.
<b>F3</b>	Anti-freeze mode in progress. Boiler functioning to restore the minimum safety temperature against boiler freezing.
<b>CAR OFF</b>	Remote Control (Optional) off.
<b>F7</b>	With Aqua Celeris active, the boiler starts when there is the necessity to pre-heat the water contained in the mini storage tank, thus guaranteeing almost instantaneous distribution of domestic hot water.
<b>F4</b>	Postventilation in progress. Fan in function after a request for domestic hot water or central heating in order to evacuate residual flue gases.
<b>F5</b>	Postcirculation in progress. Pump in function after a request for domestic hot water or central heating in order to cool the primary circuit.
<b>P33</b>	With Remote Control (Optional) or environment thermostat (TA) (Optional) in block, the boiler functions all the same in central heating mode. (Can be activated through the "Customisation" menu. It allows to activate the central heating even if the Remote Control or TA are out of order).
<b>STOP</b>	Reset attempts finished. Wait for 1 hour to re-acquire 1 attempt. (See Ignition block).
<b>ERR xx</b>	Anomaly present with relative error code. The boiler does not work. (see troubleshooting paragraph).
<b>SET</b>	During the rotation of the domestic hot water temperature selector switch (1 Fig. 2-1) view the state of the adjustment of the domestic hot water temperature in progress.
	During rotation of the central heating selector switch (3 Fig. 2-1) the adjustment status of the boiler flow temperature for central heating is displayed.
	In presence of the external probe (optional) replace the "SET" item. The value that appears is the correction of the flow temperature with respect to the functioning curve set by the external probe. See OFFSET on external probe graphics (Fig. 1-7).
<b>F8</b>	System deaeration in progress. During this phase, which lasts 18 hours, the boiler pump is started at pre-established intervals, thus allowing deaeration of the heating system.

INSTALLER

USER

MAINTENANCE TECHNICIAN

**2.5 USING THE BOILER.**

Before ignition make sure the central heating system is filled with water and that the manometer (23) indicates a pressure of 1 - 1.2 bar. Open the gas cock upstream from the boiler.

With the boiler off, only the stand-by symbol (10) appears on the display. By pressing the (⏻) button the boiler switches on.

Once the boiler is on, by pressing button "A" repeatedly, the functioning mode changes and pass alternatively from summer functioning mode (☀️) and winter functioning mode (❄️).

• **Summer** (☀️): in this mode the boiler functions only to heat domestic hot water. The temperature is set using the selector switch (1) and the relative temperature is shown on the display (24) by means of the indicator (2) and the "SET" indication appears. (see figure). By turning the selector switch (1) in a clockwise direction the temperature increases and in an anti-clockwise direction it decreases.

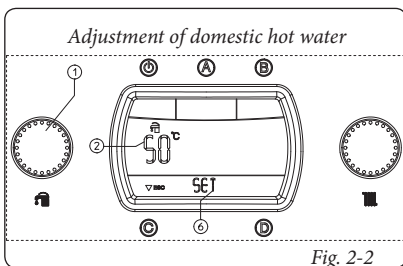

Fig. 2-2

During the heating of the domestic hot water "DHW ON" appears on the display (24) on the status indicator (6) and at the same time as burner ignition the flame presence indicator switches on (8) with relative power scale and the indicator (9 and 7) with the instantaneous outlet temperature from the primary heat exchanger.

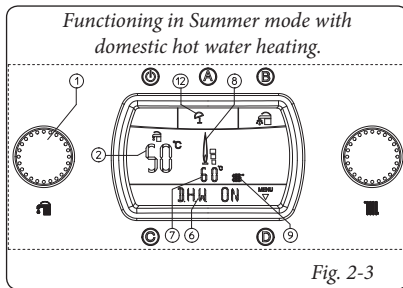

Fig. 2-3

• **Winter** (❄️): in this mode the boiler functions both for heating domestic hot water and heating the environment. The temperature of the domestic hot water is always adjusted using the selector switch (1), the heating temperature is adjusted using the selector switch (3) and the relative temperature is shown on the display (24) using the indicator (4) and the "SET" indication appears. (see figure). By turning the selector switch (3) in a clockwise direction the temperature increases and in an anti-clockwise direction it decreases.

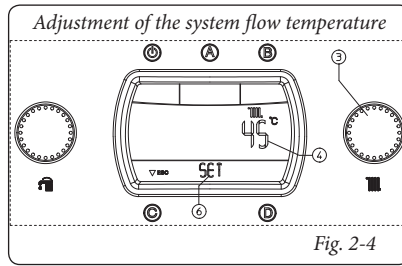

Fig. 2-4

During the request for central heating "CH ON" appears on the display (24) on the status indicator (6) and at the same time as burner ignition the flame presence indicator switches on (8) with relative power scale and the indicator (9 and 7) with the instantaneous outlet temperature from the primary heat exchanger. In the central heating phase, if the temperature of the water contained in the system is sufficient to heat the radiators, the boiler can only function with the activation of the boiler pump.

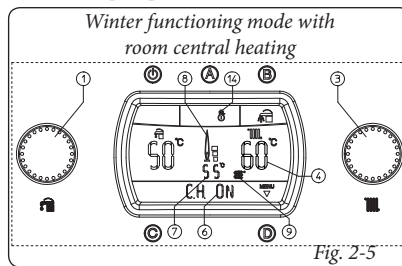

Fig. 2-5

• **Operation with Comando Amico Remoto remote control v2 (CARv2) (Optional).** In the case of connection to the CAR remote control v2, the boiler automatically detects the display and the symbol appears on the display (☑️).



From this moment all controls and adjustments are referred to the CAR remote control v2. The stand-by button "⏻", the Reset button "C", the menu entry button "D" and the Aqua Celeris button "B" however remain active.

**Attention:** if the boiler is put in stand-by mode (10) on the CARv2 the "ERR>CM" connection error symbol will appear on the CARv2. The CAR is however powered constantly so as not to lose memorised programs.

• **Operation with Super Comando Amico Remoto remote control (Super CAR) (Optional).** In the case of connection to the Super CAR remote control, the boiler automatically detects the display and the symbol appears on the display (☑️).

From this moment it is possible to make adjustments indifferently from the Super CAR remote control or the boiler. Except for the room heating temperature that is shown on the display but managed by the Super RFC.

**Attention:** If the boiler is put into stand-by (10) the "ERR>CM" connection error symbol will appear on the Super CAR. The Super CAR is however powered constantly so as not to lose memorised programs.

• **Aqua Celeris Function.** By pressing button "B" the Aqua Celeris function is activated, which is marked by the switch-on of the symbol (15) on the display (24). The enabled function keeps the water contained in the mini storage tank always hot, thus guaranteeing an almost instantaneous distribution of domestic hot water.

• **Functioning with external probe (part. 18) optional.** In the case of a system with optional external probe, the boiler flow temperature for room central heating is managed by the external probe depending on the external temperature measured (Par. 1.6 and par. 3.8 under "P66"). It is possible to modify the delivery temperature from -15°C to +15°C with respect to the adjustment curve (see graphics fig. 1-8 Offset value). This correction, which can be activated using selector switch (3) is kept active for any external temperature measured. The modification of the offset temperature is displayed using the indicator (7). The indicator (4) shows the current delivery temperature and after a few seconds from the modification it is updated with the new correction. The "SET" indication appears on the display (see figure). By turning the selector switch (1) in a clockwise direction the temperature increases and in an anti-clockwise direction it decreases.

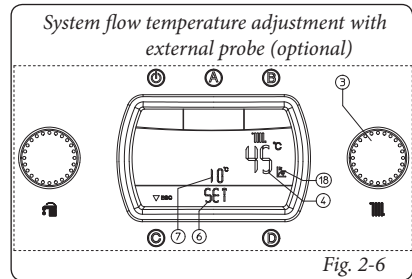

Fig. 2-6

During the request for central heating "CH" appears on the display (24) on the status indicator (6) and at the same time as burner ignition the flame presence indicator switches on (8) with relative power scale and the indicator (9 and 7) with the instantaneous outlet temperature from the primary heat exchanger. In the central heating phase, if the temperature of the water contained in the system is sufficient to heat the radiators, the boiler can only function with the activation of the boiler pump.

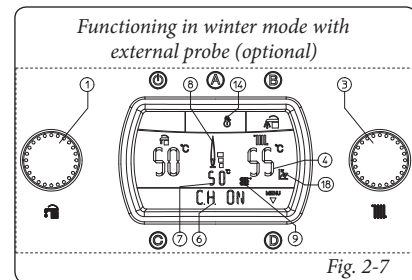

Fig. 2-7

From this moment the boiler functions automatically. With no demand for heat (heating or domestic hot water production) the boiler goes to "standby" function, equivalent to the boiler being powered without presence of flame.

**N.B.:** the boiler may start-up automatically if the anti-freeze function is activated.(13). Moreover, the boiler can function for a brief period of time after a withdrawal of domestic hot water in order to take the domestic hot water temperature back into temperature.

**Attention:** with the boiler in stand-by mode (⏻) hot water cannot be produced and the safety systems cannot be guaranteed, such as: pump anti-block, anti-freeze and three way anti-block.

## 2.6 FAULT AND ANOMALY SIGNALS.

The Victrix Superior TOP boiler signals any anomalies by the flashing symbol (5) along with the "ERRxx" indication on the indicator (6) where "xx" corresponds to the error code described in the following table. On any remote control the error code will be displayed by means of the same numerical code number represented according to the following example (e.g. CAR<sup>V2</sup> = Exx, Super CAR = ERR>xx).

Anomaly signalled	Error code
No ignition block	01
Safety thermostat block (over-heating), flame control anomaly	02
Flue safety thermostat block	03
Contacts resistance block	04
Flow probe anomaly	05
Domestic hot water probe anomaly	06
Maximum No of resets.	08
Insufficient system pressure	10
Domestic hot water inlet probe anomaly	12
Configuration error	15
Fan anomaly	16
Parasite flame block	20
Return probe anomaly	23
Push button control panel anomaly	24
Block due to flue gas temperature gradient intervention	25
Insufficient circulation	27
Flue probe anomaly	29
Loss of remote control communication	31
Low power supply voltage	37
Loss of flame signal	38
ΔT high	45
Burner power limitation	47
High temperature block on return probe	49

**Attention:** the error codes 31 to 38 are not shown on the CAR<sup>V2</sup> and Super CAR display, general code 22 is displayed in its place.

**Attention:** The anomaly can be reset up to 5 successive times, after which the function is inhibited for at least one hour. One attempt is gained every hour for a maximum of 5 attempts. By switching the appliance off and on again, the 5 attempts are re-acquired.

**Ignition block.** The boiler ignites automatically with each demand for room central heating or hot water production. If this does not occur within 10 seconds, the boiler remains in

stand-by for 30 seconds; try again and if the second attempt fails it will go into "ignition block" (ERR01). To eliminate "ignition block" the Reset button "C" must be pressed. On commissioning or after extended inactivity it may be necessary to eliminate the "ignition block". If this phenomenon occurs frequently, contact a qualified technician for assistance (e.g. Immergas After-Sales Technical Assistance Service).

**Safety thermostat block (over-heating).** During operation, if a fault causes excessive overheating internally, or an anomaly occurs in the flame control section, an overheating block is triggered in the boiler (ERR02). To eliminate "over-temperature block" the Reset button "C" must be pressed. If this phenomenon occurs frequently, contact a qualified technician for assistance (e.g. Immergas After-Sales Technical Assistance Service).

**Flue safety thermostat block.** This occurs in the case of partial internal obstruction (due to the presence of lime scale or slurry) or external blocking should occur (combustion residues) to the condensation module. To eliminate the "flue thermostat block" the Reset button "C" must be pressed. Call an authorised technician to remove the obstructions (e.g. Immergas After-sales Service).

**Contacts resistance block.** To eliminate the "flue thermostat block" the Reset button "C" must be pressed. Call an authorised technician to remove the obstructions (e.g. Immergas After-sales Service). The boiler does not start and a technician must be called (e.g. Immergas After-Sales Service).

**Flow probe anomaly.** If the board detects an anomaly on the system NTC delivery probe, the boiler will not start; contact a qualified technician for assistance (e.g. Immergas After-Sales Service).

**Delivery probe anomaly.** If the board detects an anomaly on the domestic hot water NTC probe, the boiler signals the anomaly. In this case the boiler continues to produce domestic hot water but not with optimal performance. Moreover, the anti-freeze function is prevented and an authorised technician must be called (e.g. Immergas After-Sales Service).

**Maximum No of resets.** Available number of resets already made.

**Insufficient system pressure.** Water pressure inside the central heating system that is sufficient to guarantee the correct functioning of the boiler is not detected. Check on the boiler manometer (1) that the system pressure is between 1÷1.2 bar and restore the correct pressure if necessary.

**Domestic hot water inlet probe anomaly.** If the board detects an anomaly on the domestic hot water inlet probe, the boiler continues to produce domestic hot water but not with optimal performance. A qualified technician must be called (e.g. Immergas After-Sales Service).

**Configuration error.** If the board detects an anomaly or in congruency on the electric wiring, the boiler will not start. If normal conditions are restored the boiler restarts without having to be reset. If this anomaly persists, contact a qualified technician for assistance (e.g. Immergas After-Sales Service).

**Fan anomaly.** This occurs if the fan has a mechanical or electrical fault. To eliminate the "fan anomaly" the Reset button "C" must be pressed. If this anomaly persists, contact a qualified technician for assistance (e.g. Immergas After-Sales Service).

**Parasite flame block.** This occurs in case of a leak on the detection circuit or anomaly in the flame control unit. The boiler can be reset in order to allow a new ignition attempt. If the boiler does not start, contact a qualified technician for assistance (e.g. Immergas After-Sales Service).

**Return probe anomaly.** If the board detects an anomaly on the system return NTC probe, the boiler will not start; contact a qualified technician for assistance (e.g. Immergas After-Sales Technical Assistance Service).

**Push button control panel anomaly.** This occurs when the P.C.B. detects an anomaly on the push button control panel. If normal conditions are restored the boiler restarts without having to be reset. If this anomaly persists, contact a qualified technician for assistance (e.g. Immergas After-Sales Service).

**Block due to flue gas temperature gradient intervention.** If the board detects a rapid increase of flue gas temperature probably due to a blocked pump or lack of water in the heat exchanger, the boiler blocks due to the flue gas temperature gradient intervention. To eliminate it, the Reset button (C) must be pressed. If this phenomenon occurs frequently, contact a qualified technician for assistance (e.g. Immergas After-Sales Technical Assistance Service).

**Insufficient circulation.** This occurs if there is overheating in the boiler due to insufficient water circulating in the primary circuit; the causes can be:

- low system circulation; check that no shut-off devices are closed on the heating circuit and that the system is free of air (deaerated);
- circulating pump blocked; free the circulating pump.

If this phenomenon occurs frequently, contact a qualified technician for assistance (e.g. Immergas After-Sales Technical Assistance Service).

**Flue probe anomaly.** If the board detects an anomaly on the flue probe, the boiler will not start; contact a qualified technician for assistance (e.g. Immergas After-Sales Technical Assistance Service).

**Loss of remote control communication.** This occurs in the case of connection to a remote control that is not compatible or if there is a loss of communication between the boiler and CAR remote control<sup>V2</sup> or Super CAR remote control. Try the connection procedure again by turning the boiler off and then back on again. If the Remote Control is still not detected on re-starting the boiler will switch to local operating mode, i.e. using the controls on the boiler itself. In this case the boiler cannot activate the "Central heating" function. To make the boiler function in "Central heating" mode, activate the "P33" function present inside the "M3" menu. If this phenomenon occurs frequently, contact a qualified technician for assistance (e.g. Immergas After-Sales Technical Assistance Service).

**Low power supply voltage** This occurs when the power supply voltage is lower than the allowed limits for the correct functioning of the boiler. If normal conditions are restored, the boiler re-starts without having to be reset. If this phenomenon occurs frequently, contact a qualified technician for assistance (e.g. Immergas After-Sales Technical Assistance Service).

**Loss of flame signal.** This occurs when the boiler is ignited correctly and the burner flame switches off unexpectedly; a new attempt at ignition is performed and if normal conditions are restored, the boiler does not have to be reset (this anomaly can be checked in the list of errors "P19" present in the "M1" menu). If this phenomenon occurs frequently, contact a qualified technician for assistance (e.g. Immergas After-Sales Technical Assistance Service).

**High  $\Delta T$ .** If the board detects a sudden and unexpected rise in  $\Delta T$  between the system flow probe and return probe, the boiler limits the burner output to prevent damaging the condensing module; when the correct  $\Delta T$  has been restored, the boiler returns to normal operation. Make sure there is water circulating in the boiler, that the pump is configured according to system requirements and that the return probe works properly. If this phenomenon occurs frequently, contact a qualified technician for assistance (e.g. Immergas After-Sales Technical Assistance Service).

**Burner power limitation.** In the event that the boiler is blocked, the boiler reduces the power supplied to prevent damaging it; a qualified technician must be called (e.g. Immergas After-Sales Service).

**High temperature block on return probe.** This occurs when the heat exchanger return circuit reaches too high a temperature. Make sure that water circulates properly in the boiler and that the three-way valve works properly. To eliminate it, the Reset button (C) must be pressed. If this phenomenon occurs frequently, contact a qualified technician for assistance (e.g. Immergas After-Sales Technical Assistance Service).

**Signalling and diagnostics - Display of the Remote Controls (Optional).** During normal boiler functioning the remote control display shows (CAR<sup>v2</sup> remote control or Super CAR remote control) the room temperature value; in the case of malfunctioning or anomaly, the display of the temperature is replaced by the relative error code present in the table (Par. 2-6).

## 2.7 BOILER SHUTDOWN.

Switch the boiler off by pressing the "⏻" button, disconnect the onnipolar switch outside of the boiler and close the gas cock upstream from the appliance. Never leave the boiler switched on if left unused for prolonged periods.

## 2.8 RESTORE HEATING SYSTEM PRESSURE.

Periodically check the system water pressure. The boiler manometer should read a pressure between 1 and 1.2 bar.

*If the pressure falls below 1 bar (with the circuit cool) restore normal pressure via the valve located at the bottom of the boiler (Fig. 2-8).*

**N.B.:** close the valve after the operation.

If pressure values reach around 3 bar the safety valve may be activated.

In this case contact a professional technician for assistance.

In the event of frequent pressure drops, contact qualified staff for assistance to eliminate the possible system leakage.

## 2.9 DRAINING THE SYSTEM.

To drain the boiler, use the special draining valve (Fig. 2-8).

Before draining, ensure that the filling valve is closed.

## 2.10 ANTI-FREEZE PROTECTION.

The "Victrix Superior TOP" series boiler has an anti-freeze function that switches on automatically when the temperature falls below 4°C (standard protection to minimum temperature of -3°C). All information relative to the anti-freeze protection is stated in Par. 1.3. In order to guarantee the integrity of the appliance and the domestic hot water heating system in zones where the temperature falls below zero, we recommend the central heating system is protected using anti-freeze liquid and installation of the Immergas Anti-freeze Kit in the boiler. In the case of prolonged inactivity (second case), we also recommend that:

- the electric power supply is disconnected;
- the heating circuit and boiler domestic water circuit must be drained. In systems that are drained frequently, filling must be carried out with suitably treated water to eliminate hardness that can cause lime-scale.

## 2.11 CASE CLEANING.

Use damp cloths and neutral detergent to clean the boiler casing. Never use abrasive or powder detergents.

## 2.12 DECOMMISSIONING.

In the event of permanent shutdown of the boiler, contact professional staff for the procedures and ensure that the electrical, water and gas supply lines are shut off and disconnected.

### Bottom view.

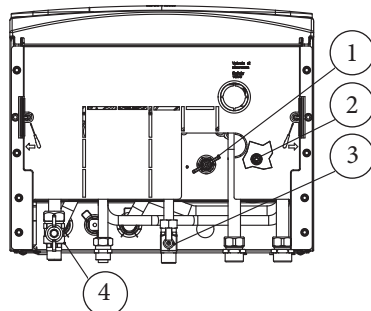

#### Key:

- 1 - System filling valve
- 2 - System draining valve
- 3 - Domestic hot water inlet valve
- 4 - Gas cock

Fig. 2-8

**2.13 PARAMETERS AND INFORMATION MENU.**

By pressing the button "D" it is possible to access a menu divided into three main parts:

- Information "M1"
- Customisations "M3"
- "M5" configurations, menu reserved for the technician and for which a password is required (See "Technician" chapter).

- "M9" setting.

By turning the heating temperature selector switch (3) scroll through the menu items. By pressing button "D" access the various levels of the menu and the choice of parameters is confirmed. Press button "C" to go back one level.

**Information Menu.** This menu contains the various information relative to boiler functioning:

1 <sup>st</sup> Level	Button	2 <sup>nd</sup> Level	Button	3 <sup>rd</sup> Level	Button	Description
M1	D ⇨ ⇨ C	P11	D ⇨ ⇨ C			View the management software version of the P.C.B. installed in the boiler.
		P12				View the total functioning hours of the boiler.
		P13				View the number of burner ignitions.
		P14 (with optional external probe present) - - - (without external probe (optional))	D ⇨ ⇨ C	P14/A		View the current external temperature (if optional external probe present).
				P14/B		View the minimum external temperature recorded (if optional external probe present).
				P14/C		View the maximum external temperature recorded (if optional external probe present).
				RESET	D x select ⇨ C	By pressing button "D" the MIN and MAX temperatures measured are zeroed.
		P15	D ⇨ ⇨ C			View the value of the domestic hot water flow rate from the flow meter.
		P17				View the percentage speed in instantaneous revs.of the fan (in RPM).
		P18				View the instantaneous speed of the pump (in %).
P19	View the last 5 events that caused boiler shutdown. Indicator (6) shows the sequential number from 1 to 5 and on indicator (7) the relative error code. By pressing button "D" repeatedly it is possible to view the functioning time and the number of ignitions at which the anomaly occurred.					

**Customisation menu.** This menu contains all functioning options that can be customised. (The first item of the various options that appears inside the parameter is that selected by default).

**Attention:**if the international language is to be restored (A-1), proceed as follows:

- Press button "D" to enter the configuration menu.
- Turn selector switch "3" to "PERSONAL".
- Press button "D" to confirm.
- Turn selector switch "3" to "DATI".
- Press button "D" to confirm.

- Turn selector switch "3" to "LINGUA".
- Press button "D" to confirm.
- Turn selector switch "3" to "A-1".
- Press button "D" to confirm.

At this point the international items indicated in the menu tables appear on the display.

1 <sup>st</sup> Level	Button	2 <sup>nd</sup> Level	Button	3 <sup>rd</sup> Level	Button	4 <sup>th</sup> Level	Button	Description
M3	D ⇨ ⇨ C	P31	D ⇨ ⇨ C	AUTO (Default)	D x select ⇨ C			The display lights up when the burner is ignited and when the controls are accessed, it remains on for 5 seconds after the last operation performed.
				ON				The display is always lit up.
				OFF				The display only lights up when the controls are accessed and remains on for 5 seconds after the last operation performed.
		P32	D ⇨ ⇨ C	P32/B	D ⇨ ⇨ C	ITALIANO	D x select ⇨ C	All descriptions are given in Italian.
						A-1 (Default)		All descriptions are given in alphanumerical format.
P33	D ⇨ ⇨ C	OFF (Default)	D x select ⇨ C			In winter mode, by activating this function it is possible to activate the room heating function even if the eventual Remote Control or TA are out of service.		
		ON						
RESET	D x select ⇨ C					By pressing button "D" the customisations made are zeroed, restoring the values "P31" in "ILL. AUTO" and "P32/B" in "ITALIANO".		

**Zones Menu.** The menu zone is only activated if the board detects a connection to a board on an additional zone (optional). This menu contains the temperature functioning settings in the additional zones.

1 <sup>st</sup> Level	Button	2 <sup>nd</sup> Level	Button	Description
M9	D ⇨ ⇨ C	P91	D ⇨ ⇨ C	Displays the current temperature of the low temperature zone number 2.
		P92	D ⇨ ⇨ C	Displays the current temperature of the low temperature zone number 3 (Optional).
	P93	D ⇨ ⇨ C	Defines the flow temperature of the zone number 2 at low temperature. With external probe (Optional) present the flow temperature can be corrected with respect to the functioning curve set by the external probe. See OFFSET on the external probe graphics (Fig. 1-8) by modifying the temperature from -15°C to +15°C.	
	P94	D x select ⇨ C	It defines the flow temperature of the zone number 3 at low temperature (Optional). With external probe (Optional) present the flow temperature can be corrected with respect to the functioning curve set by the external probe. See OFFSET on the external probe graphics (Fig. 1-8) by modifying the temperature from -15°C to +15°C.	

### 3 BOILER COMMISSIONING (INITIAL CHECK)

To commission the boiler:

- ensure that the declaration of conformity of installation is supplied with the appliance;
- ensure that the type of gas used corresponds to boiler settings;
- check connection to a 230V-50Hz power mains, correct L-N polarity and the earthing connection;
- make sure the heating system is filled with water and that the manometer indicates a pressure of 1±1.2 bar;
- switch the boiler on and ensure correct ignition;

- check the  $\Delta p$  gas values in domestic hot water and heating modes;
- check the  $CO_2$  in the combustion products at maximum and minimum flow rate;
- check activation of the safety device in the event of no gas, as well as the relative activation time;
- check activation of the main switch located upstream from the boiler and in the boiler;
- check that the intake and/or exhaust terminals are not blocked;
- ensure activation of all adjustment devices;
- seal the gas flow rate regulation devices (if settings are modified);
- ensure production of domestic hot water;

- ensure sealing efficiency of water circuits;
  - check ventilation and/or aeration of the installation room where provided.
- If even only a single safety check offers a negative result, do not commission the system.

INSTALLER

USER

MAINTENANCE TECHNICIAN

#### 3.1 HYDRAULIC DIAGRAM.

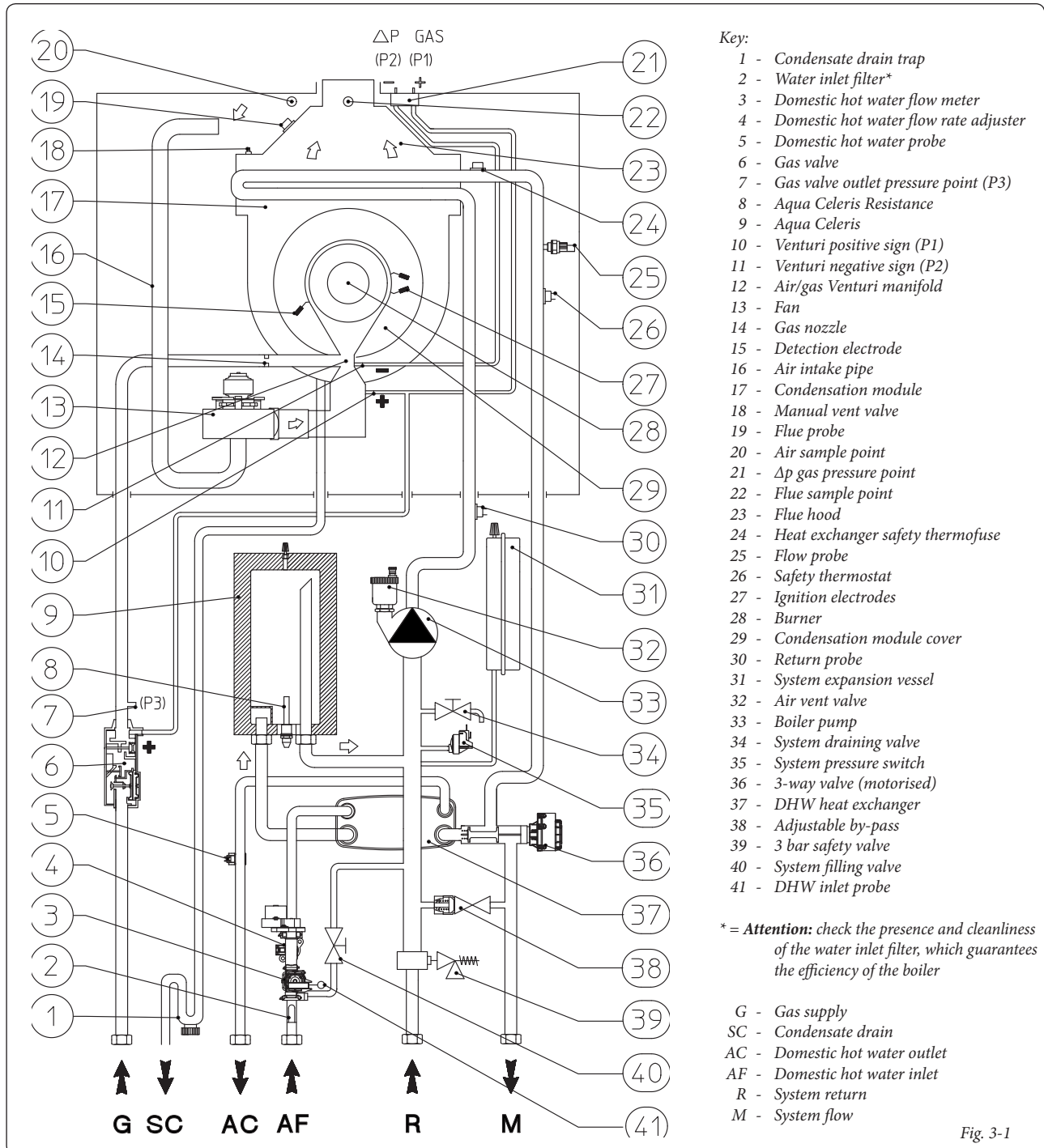
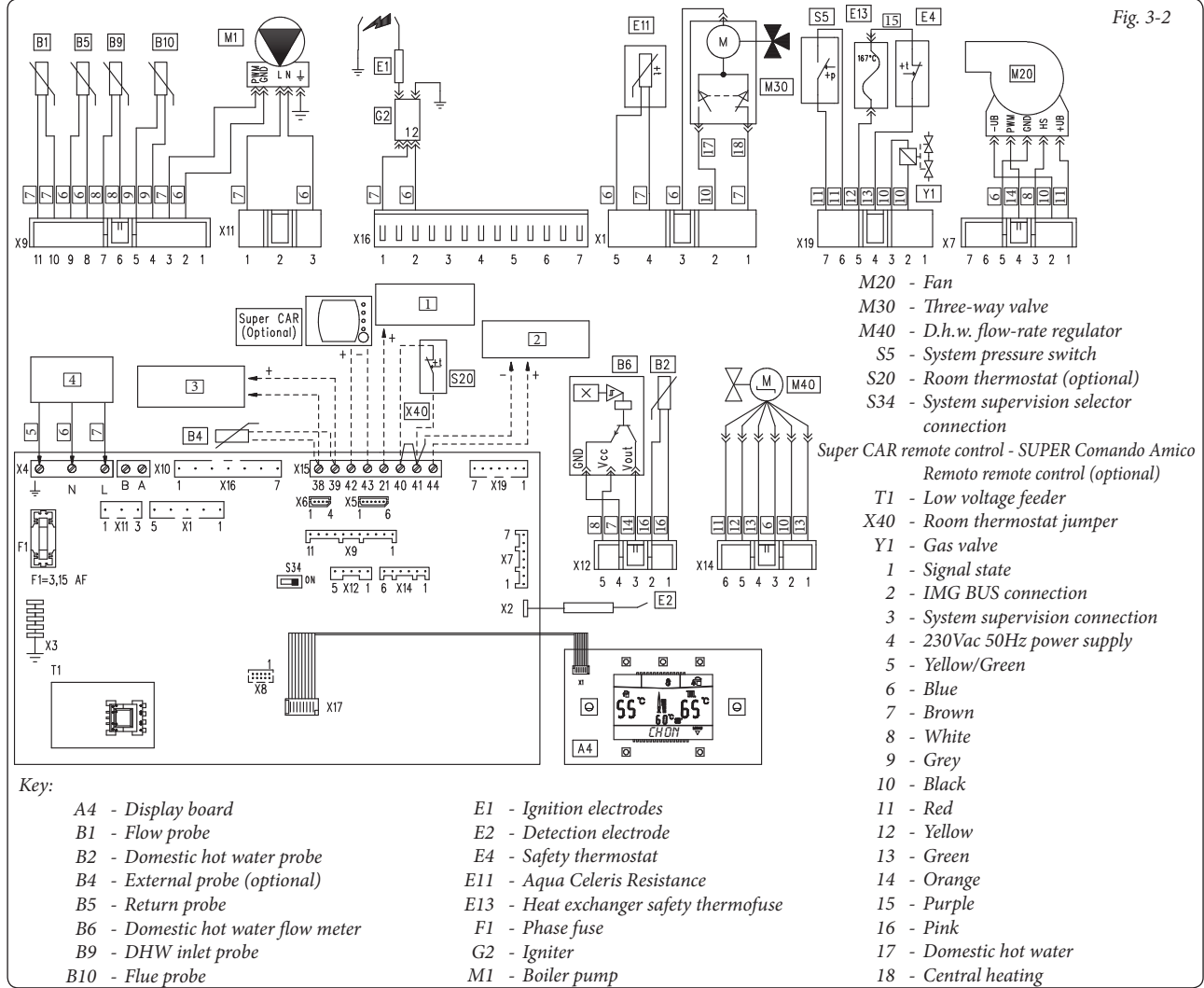

Fig. 3-1

**3.2 WIRING DIAGRAM.**



**Remote controls:** the boiler is designed to use the Comando Amico Remoto remote control<sup>V2</sup> (CAR<sup>V2</sup>) or as an alternative to the Super Comando Amico Remoto remote control (Super CAR), which must be connected to clamps 42 and 43 of connector X15 on the P.C.B., respecting polarity and eliminating jumper X40.

**Room thermostat:** the boiler is designed to use the Room Thermostat (S20). Connect it to clamps 40 – 41 eliminating jumper X40.

The connector X5 is used for the connection to the relay P.C.B.

The connector X6 is for connection to a personal computer.

The connector X8 is used for software updating operations.

The S34 selector defines the functioning of the boiler with the system supervisor or with the external probe:

S34 Off = operation with system supervisor  
 S34 On = operation with external probe.

**3.3 TROUBLESHOOTING.**

**N.B.:** maintenance interventions must be carried out by a qualified technician (e.g. Immergas After-Sales Technical Assistance Service).

- Smell of gas. Caused by leakage from gas circuit pipelines. Check sealing efficiency of gas intake circuit.
- Repeated ignition blocks. No gas, check the presence of pressure in the network and that the gas adduction valve is open. Incorrect adjustment of the gas valve, check the correct calibration of the gas valve.
- Irregular combustion or noisiness. This may be caused by: a dirty burner, incorrect combustion parameters, intake-exhaust terminal not correctly installed. Clean the above components and ensure correct installation of the terminal, check correct setting of the gas valve (Off-Set setting) and correct percentage of CO<sub>2</sub> in flue gases.
- Frequent activation of the temperature overload thermostat. It can depend on the lack of water in the boiler, little water circulation in the system or blocked pump. Check on the manometer that the system pressure is within established limits. Check that the radiator valves are not closed and also the functionality of the pump.

- Siphon blocked. This may be caused by dirt or combustion products deposited inside. Check, by means of the condensate drain cap, that there are no residues of material blocking the flow of condensate.
- Heat exchanger blocked. This may be caused by the trap being blocked. Check, by means of the condensate drain cap, that there are no residues of material blocking the flow of condensate.
- Noise due to air in the system. Check opening of the special air vent valve cap (Part. 27 Fig. 1-29). Make sure the system pressure and expansion vessel pre-charge values are within the set limits; The factory-set pressure values of the expansion vessel must be 1.0 bar, the value of system pressure must be between 1 and 1.2 bar.
- Noise due to air inside the condensation module. Use the manual air vent valve (Part. 13 Fig. 1-29) to eliminate any air present in the condensation module. When the operation has been performed, close the manual vent valve.
- Low circulation. The boiler leaves the factory calibrated with the pump set on Auto and ΔT between constant flow and return on 15°C. Check if this ΔT is correct for the system and if needed modify the pump settings.

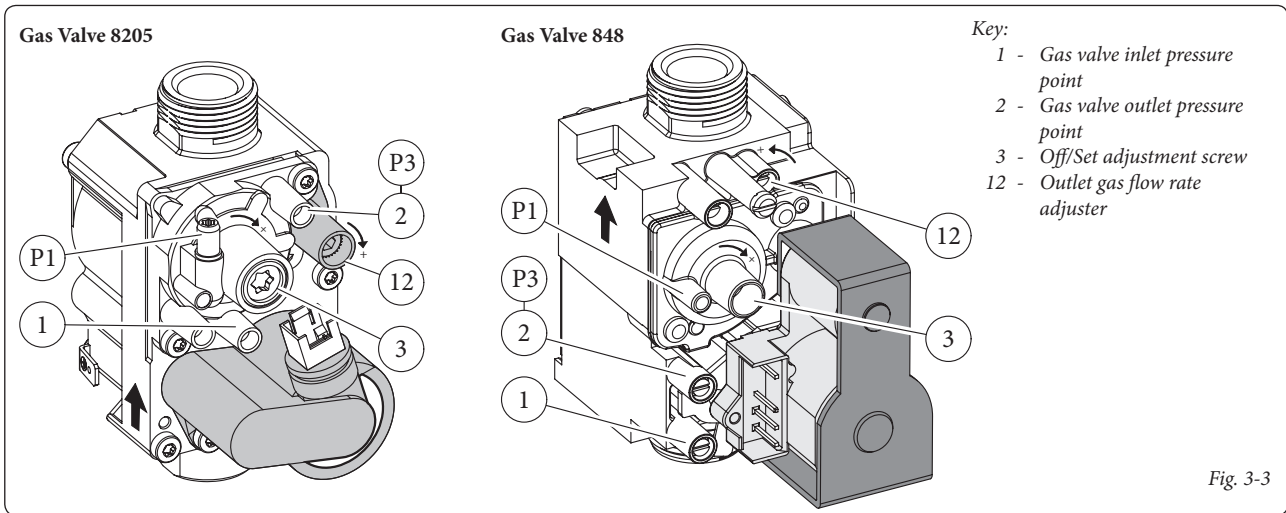

Fig. 3-3

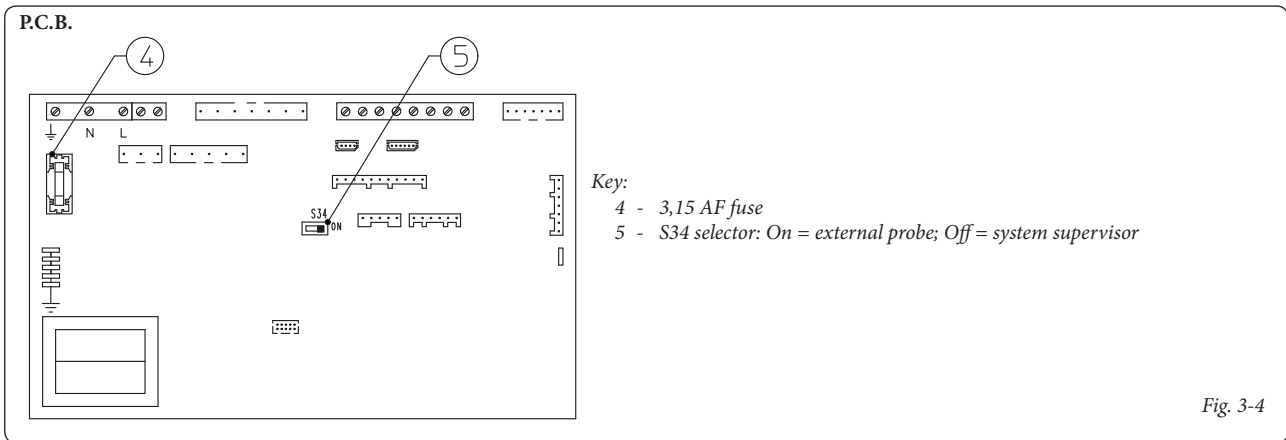

Fig. 3-4

**3.4 CONVERTING THE BOILER TO OTHER TYPES OF GAS.**

If the boiler has to be converted to a different gas type to that specified on the data plate, request the relative conversion kit for quick and easy conversion.

Boiler conversion must be carried out by a qualified technician (e.g. Immergas After-Sales Technical Assistance Service).

To convert to another type of gas the following operations are required:

- remove the voltage from the appliance;
- replace the nozzle located between the gas pipe and gas/air mixing sleeve (Part. 6 Fig. 1-29), taking care to remove the voltage from the appliance during this operation;
- apply voltage to the appliance;
- calibrate the number of fan revs. (Par. 3.5);
- adjust the correct air/gas ratio (Par. 3.6);
- seal the gas flow rate devices (if adjusted);
- after completing conversion, apply the sticker, present in the conversion kit, near the data-plate. Using an indelible marker pen, cancel the data relative to the old type of gas.

These adjustments must be made with reference to the type of gas used, following that given in the table (Par. 3.18).

**3.5 CALIBRATION OF NUMBER OF FAN REVS.**

**Attention:** verification and calibration is necessary, in the case of transformation to other types of gas, in the extraordinary maintenance phase with replacement of the circuit board, air/gas circuit components or in the case of installations with fume extraction systems, with horizontal concentric pipe measuring more than 1 metre.

The boiler heat output is correlated to the length of the air intake and flue exhaust pipes. This decreases with the increase of pipe length. The boiler leaves the factory adjusted for minimum pipe length (1m). It is therefore necessary, especially in the case of maximum pipe extension, to check the  $\Delta p$  gas values after at least 5 minutes of burner functioning at nominal heat output, when the temperatures of the intake air and exhaust flue gases have stabilised. Adjust the nominal and minimum heat output in the domestic hot water and central heating modes according to the values in the table (Par. 3.18) using the differential manometers connected to the  $\Delta p$  gas pressure point (13 and 14 Fig. 1-29).

Enter in the M5 menu (Parag. 3.8) and adjust the ignition power "P50", meanwhile under "SERVICE" adjust the following parameters:

- boiler maximum heat output "P62";
- boiler minimum heat output "P63";
- maximum central heating output "P64";
- minimum central heating output "P65".

Below find the default settings present on the boiler:

P50	36 %	40%
P62	G20: 5100 (rpm)	LPG: 4600 (rpm)
P63	G20: 980 (rpm)	LPG: 1020 (rpm)
P64	G20: 5100 (rpm)	LPG: 4600 (rpm)
P65	G20: 980 (rpm)	LPG: 1020 (rpm)

### 3.6 ADJUSTMENT OF THE AIR-GAS RATIO.

**Attention:** the verification operations of the CO<sub>2</sub> must be carried out with the casing mounted, while the gas valve calibration operations must be carried out with the casing open and removing the voltage from the boiler.

Calibration of the minimum CO<sub>2</sub> (minimum heating power).

Enter the chimney sweep phase without withdrawing domestic hot water and take the selector switches to minimum (turn them in an anti-clockwise direction until "0" is seen on the display). to have an exact value of CO<sub>2</sub> in the flue gases the technician must insert the sampling probe to the bottom of the sample point, then check that the CO<sub>2</sub> value is that specified in the table, otherwise adjust the screw (3 Fig. 3-3) (Off-Set adjuster). To increase the CO<sub>2</sub> value, turn the adjustment screw (3) in a clockwise direction and vice versa to decrease it.

Calibration of the maximum CO<sub>2</sub> (nominal central heating power).

On completion of the adjustment of the minimum CO<sub>2</sub> keeping the chimney sweep function active, take the heating selector switch to maximum (turn it in a clockwise direction until "99" is seen on the display). To have an exact value of CO<sub>2</sub> in the flue gases the technician must insert the sampling probe to the bottom of the sample point, then check that the CO<sub>2</sub> value is that specified in the table, otherwise adjust the screw (12 Fig. 3-3) (Gas flow adjuster).

To increase the CO<sub>2</sub> value, turn the adjustment screw (12) in a clockwise direction for the 8205 gas valve and anticlockwise for the 848 gas and vice versa to decrease it.

At every adjustment variation on the screw 12 it is necessary to wait for the boiler to stabilise itself at the value set (about 30 sec.).

	CO <sub>2</sub> at nominal output (central heating)	CO <sub>2</sub> at minimum output (central heating)
G 20	9.50% ± 0.2	8.90% ± 0.2
G 30	12.20% ± 0.2	11.10% ± 0.2
G 31	10.50% ± 0.2	10.20% ± 0.2

### 3.7 CHECKS FOLLOWING CONVERSION TO ANOTHER TYPE OF GAS.

After making sure that conversion was carried out with a nozzle of suitable diameter for the type of gas used and the settings are made at the correct pressure, check that the burner flame is not too high or low and is stable (does not detach from burner).

**N.B.:** all boiler adjustment operations must be carried out by a qualified technician (e.g. Immergas Assistance Service).

### 3.8 PROGRAMMING THE P.C.B.

The Victrix Superior TOP boiler is prepared for possible programming of several operation parameters. By modifying these parameters as described below, the boiler can be adapted according to specific needs.

**Attention:** if the international language (A1) is to be restored, see the indications described in Para 2.13 ("M3" Customisations menu).

By pressing the button "D" it is possible to access the main menu, divided into three main parts:

- Information "M1" (See "User" Chapter).
- Customisations "M3" (See "User" Chapter).
- "M5" configurations, menu reserved for the technician and for which a password is required.

To access programming, press button "D", turn the central heating temperature selector switch (3) and scroll through the menu items until reaching "M5", press button "D", introduce the password and set the parameters according to requirements.

Below find the items in the "M5" menu with default parameters and possible options indicated.

By turning the heating temperature selector switch (3) scroll through the menu items. By pressing button "D" access the various levels of the menu and the choice of parameters is confirmed. Press button "C" to go back one level.

(The first item of the various options that appears inside the parameter is that selected by default).

M5 menu (password must be entered)					
1 <sup>st</sup> Level	2 <sup>nd</sup> Level	Options	Description	Default value	Value set by the technician
P50		25 ÷ 50	Set the boiler heat output in ignition phase. The value is in percentage in respect to the parameter P62.	(See par. 3.5)	
P53		P53.1	Identifies the output of the boiler on which the P.C.B. is installed P53.1 = Not used P53.2 = 26 kW (Not used on this boiler model) P53.3 = 32 kW.	Equal to boiler power	Equal to boiler power
		P53.2			
		P53.3			
P54		P54.1	Displays the temperature read on the domestic hot water probe on entry to the boiler.	-	-
		P54.2	Displays the temperature read on the domestic hot water probe on exit from the boiler.	-	-
		P54.3	Displays the temperature read on the return probe.	-	-
		P54.4	Not used on this boiler model.	-	-
P55			Displays the central heating flow temperature at which the boiler functions, calculated by the controls active on the system heat adjustment.	-	-
SERVICE	P57	AUTO	- DT = 0: proportional prevalence (see par. 1.22). - DT = 5 ÷ 25 K: ΔT constant (see par. 1.22).	AUTO 15 K	
		FIX	Fixed pump speed. (adjustable from 100% to 54%).		
	P62	4000 ÷ 5900	Set the maximum output depending on the domestic hot water, setting the speed of the fan (in RPM).	(See par. 3.5)	
	P63	900 ÷ 1500	Set the minimum output depending on the domestic hot water, setting the speed of the fan (in RPM).	(See par. 3.5)	
	P64	≤ P62	Set the minimum output depending on room heating. The value must be greater than or equal to the P62.	(See par. 3.5)	
	P65	≥ P63	Set the minimum output depending on room heating. The value must be greater than or equal to the P63.	(See par. 3.5)	
	P66	P66/A	Without the external probe (optional) it defines the minimum delivery temperature. With the external probe present it defines the minimum flow temperature corresponding to functioning with maximum external temperature (see graphics Fig. 1-8) (can be set from 20°C to 50°C). <b>N.B.:</b> to continue it is necessary to confirm the parameter (press "D" or exit from "P66" adjustments by pressing "C").	20°C	
		P66/B	Without the external probe (optional) it defines the maximum delivery temperature. With the external probe present it defines the maximum flow temperature corresponding to functioning with minimum external temperature (see graphics Fig. 1-8) (can be set from 85°C to 50°C). <b>N.B.:</b> to continue it is necessary to confirm the parameter (press "D" or exit from "P66" adjustments by pressing "C").	85°C	
		P66/C	With the external probe present it defines at which minimum external temperature the boiler must function at maximum flow temperature (see graphics Fig. 1-8) (can be set from -20°C to 0°C). <b>N.B.:</b> to continue it is necessary to confirm the parameter (press "D" or exit from "P66" adjustments by pressing "C").	-5°C	
		P66/D	With the external probe present it defines at which maximum external temperature the boiler must function at maximum flow temperature (see graphics Fig. 1-8) (can be set from 5°C to +25°C). <b>N.B.:</b> to continue it is necessary to confirm the parameter (press "D" or exit from "P66" adjustments by pressing "C").	25°C	

INSTALLER

USER

MAINTENANCE TECHNICIAN

INSTALLER

USER

MAINTENANCE TECHNICIAN

M5 menu (password must be entered)					
1 <sup>st</sup> Level	2 <sup>nd</sup> Level	Options	Description	Default value	Value set by the technician
SERVICE	P67	P67.1	In winter mode the pump is always powered and so functions continuously.	P67.2	
		P67.2	In winter mode the pump is managed by the room thermostat or by the remote control.		
		P67.3	In winter mode the pump is managed by the room thermostat or by the remote control and by the boiler flow probe.		
	P68	0s ÷ 500s	The boiler is set to ignite the burner immediately after a request for heating. In the case of particular systems (e.g. area systems with motorised thermostatic valves etc.) it could be necessary to delay switch-on.	0 seconds	
	P69	0s ÷ 255s	The boiler has an electronic timing device that prevents the burner from igniting too often in the central heating phase.	180 seconds	
	P70	0s ÷ 840s	The boiler performs an ignition ramp to arrive from minimum power to nominal heat output.	180 seconds (3 minutes)	
	P71	P71.1	OFF domestic hot water "correlated" to the switch-off of the boiler takes place on the basis of the temperature set using the domestic hot water adjustment selector switch. Solar function active, if the input domestic hot water has a sufficient temperature the boiler does not switch on.	P71.2	
		P71.2	fixed domestic hot water OFF; the boiler switches off at 65°C. Solar function deactivated.		
	P72	AUTO OFF 09 L/M 12 L/M 15 L/M	The boiler allows to set the flow rate adjuster on the various levels. Auto (automatic functioning, therefore with variable flow rate). Open (adjuster completely open therefore maximum flow rate available). 08 L/M, 10 L/M and 12 L/M (functioning with defined flow rate).	AUTO	
	RELE1 (optional)	RELE1-0	Relay 1 not used.	RELE1-1	
		RELE1-1	In a system divided into zones, relay 1 controls the main zone.		
		RELE1-2	The relay signals the intervention of boiler block ( Can be coupled to an external signalling device, not supplied).		
		RELE1-3	The relay signals that the boiler is on in heating phase. (Can be coupled with an external pump, not supplied).		
		RELE1-4	Controls the opening of an external gas valve in concomitance with an ignition request of the boiler burner.		
		RELE1-5	In case the boiler pump needs to be replaced with a traditional pump at fixed speed it is necessary to connect the new pump to the relay board.		
	RELE2 (optional)	RELE2-0	Relay 2 not used.	RELE2-0	
		RELE2-1	In a system divided into zones, relay 2 controls the secondary zone.		
		RELE2-2	The relay signals the intervention of boiler block ( Can be coupled to an external signalling device, not supplied).		
RELE2-3		The relay signals that the boiler is on in heating phase. (Can be coupled with an external pump, not supplied).			
RELE2-4		Controls the opening of an external gas valve in concomitance with an ignition request of the boiler burner.			
RELE2-5		Operation with heat pump. Coupled to the 3-5 operation of relay 3 and an interface (not supplied) allows the management of the boiler coupled to a heat pump.			
RELE2-6		In case the boiler pump needs to be replaced with a traditional pump at fixed speed it is necessary to connect the new pump to the relay board.			

M5 menu (password must be entered)					
1 <sup>st</sup> Level	2 <sup>nd</sup> Level	Options	Description	Default value	Value set by the technician
	RELE3 (optional)	RELE3-0	Relay 3 not used.	RELE3-0	
		RELE3-1	Check the storage tank recirculation pump. (not usable on this model).		
		RELE3-2	The relay signals the intervention of boiler block ( Can be coupled to an external signalling device, not supplied).		
		RELE3-3	The relay signals that the boiler is on in heating phase. (Can be coupled with an external pump, not supplied).		
		RELE3-4	Controls the opening of an external gas valve in concomitance with an ignition request of the boiler burner.		
		RELE3-5	Operation with heat pump. Coupled to the 2-5 operation of relay 2 and an interface (not supplied) allows the management of the boiler coupled to a heat pump.		
		P76	-15°C ÷ +14°C CE	With S34 = On. If the reading of the external probe is not correct it is possible to correct it in order to compensate any environmental factors. With S34 = Off and system supervisor connected, set the parameter to maximum until the CE value appears.	0°C

### 3.9 "CHIMNEY SWEEP FUNCTION" (F2).

If this function is activated it takes boiler functioning to the adjustable power of the central heating selector switch.

In this state all adjustments are excluded and only the safety thermostat and the limit thermostat remain active. To activate the chimney sweep press the Reset button "C" for a time between 8 and 15 seconds in absence of domestic hot water and heating requests. Its activation is signalled by the relative symbol (22 Fig. 2-1). This function allows the technician to check the combustion parameters. After the checks deactivate the function, switching the boiler off and then on again using the Stand-by button.

### 3.10 PUMP ANTI-BLOCK FUNCTION.

The boiler has a function that starts the pump at least once every 24 hours for the duration of 30 seconds in order to reduce the risk of the pump becoming blocked due to prolonged inactivity.

### 3.11 THREE-WAY ANTI-BLOCK FUNCTION.

Both in "domestic hot water" and in "domestic hot water-central heating" phase the boiler is equipped with a function that starts the three-way motorised group 24 hours after it was last in operation, running it for a full cycle so as to reduce the risk of the three-way group becoming blocked due to prolonged inactivity.

### 3.12 RADIATORS ANTI-FREEZE FUNCTION.

If the system return water temperature is near to freezing, the boiler starts up until reaching a safe temperature.

### 3.13 P.C.B. PERIODICAL SELF-CHECK.

During functioning in heating mode or with boiler in standby, the function activates every 18 hours after the last boiler check/power supply. In case of functioning in domestic hot water mode the self-check starts within 10 minutes after the end of the withdrawing in progress, for duration of approx. 10 seconds.

**N.B.:** during self-check, the boiler remains off.

### 3.14 AUTOMATIC VENT FUNCTION.

In the case of new heating systems and in particular mode for floor systems, it is very important that deaeration is performed correctly. To activate the "F8" function, press buttons "A and B" at the same time (Fig. 2-1) for 5 seconds with boiler in stand-by. The function consists in the cyclic activation of the pump (100 s ON, 20 s OFF) and the 3-way valve (120 s domestic hot water, 120 s central heating). The function ends after 18 hours or by switching the boiler on using the ignition button "⏻".

### 3.15 SOLAR PANELS COUPLING FUNCTION.

The boiler is set-up to receive pre-heated water from a system of solar panels up to a maximum temperature of 65 °C. In the case of use with higher temperatures it is recommended to install a mixing valve on the hydraulic circuit upstream from the boiler. Set the "P 71" function on "P 71.1" (Par. 3.8).

When the boiler inlet water is at a temperature that is equal or greater with respect to that set by the domestic hot water selector switch "SET", the boiler does not switch on.

### 3.16 YEARLY CONTROL AND MAINTENANCE OF THE APPLIANCE.

The following checks and maintenance should be performed at least once a year.

- Clean the flue side of the heat exchanger.
- Clean the main burner.
- Check correct ignition and functioning.
- Ensure correct calibration of the burner in domestic water and heating phases.
- Check correct functioning of appliance control and adjustment devices and in particular:
  - the intervention of main electrical switch on the boiler;
  - system control thermostat intervention;
  - domestic hot water control thermostat intervention.
- Check sealing efficiency of gas circuit and the internal system.
- Check intervention of the device against no gas ionization flame control:
  - check that the relative intervention time is less than 10 seconds.
- Visually check for water leaks or oxidation from/on connections and traces of condensate residues inside the sealed chamber.
- Check, by means of the condensate drain cap, that there are no residues of material blocking the flow of condensate.
- Check contents of the condensate drain trap.
- Visually check that the water safety drain valve is not blocked.
- Check that, after discharging system pressure and bringing it to zero (read on boiler manometer), the expansion vessel charge is at 1.0 bar.
- Check that the system static pressure (with system cold and after refilling the system by means of the filler cock) is between 1 and 1.2 bar.

- Check visually that the safety and control devices have not been tampered with and/or shorted, in particular:
  - temperature safety thermostat;
- Check the condition and integrity of the electrical system and in particular:
  - electrical power cables must be inside the fairleads;
  - there must be no traces of blackening or burning.

**N.B.:** on occasion of periodical maintenance of the appliance it is appropriate also to check and perform maintenance on the heating system, in compliance with that indicated by the regulations in force.

**3.17 CASING REMOVAL.**

To facilitate boiler maintenance the casing can be completely removed as follows:

- disassemble the front (1) of the boiler by loosening screw (2) by 1/4 turn, push the front upwards while pulling downwards at the same time to release from the lateral (3) and upper (4) hooks;
- undo the 2 screws (5) of the control panel (6);
- tilt the control panel (6) pulling it towards yourself ( figure);
- remove the sides (7) loosening the screws (8), push slightly upwards in a way to release the side from the seat (9) and pull towards yourself (see figure);

- remove the lower grid (10) removing it from the two seats (11) by inserting a screwdriver into the relevant seat marked on the grid and using it as a lever as represented in the figure.

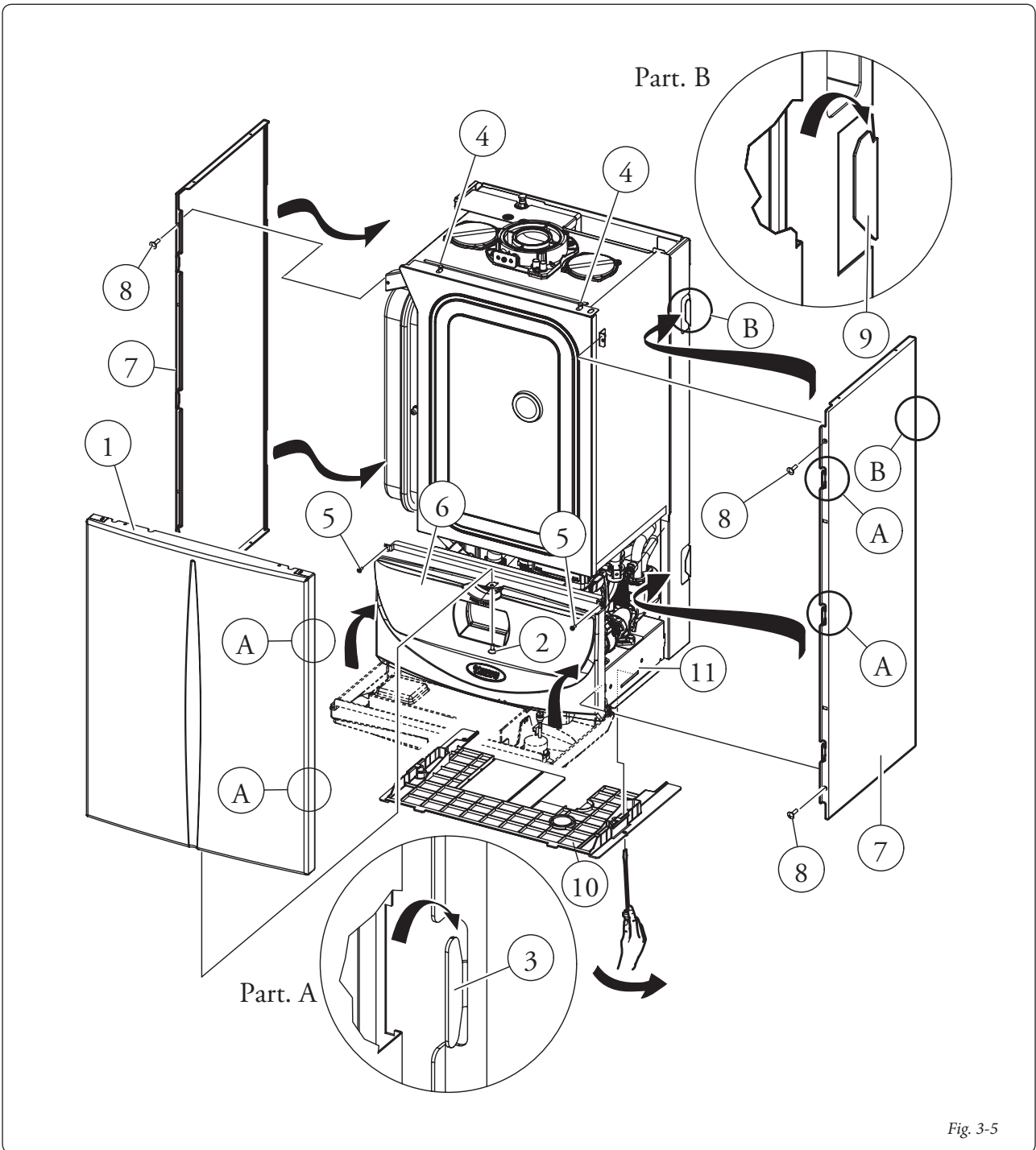

Fig. 3-5

### 3.18 VARIABLE HEAT POWER.

**N.B.:** the pressures indicated in the table represent the differences of pressures at the ends of the Venturi mixer and can be measured from the pressure point in the upper part of the

sealed chamber (see pressure test 32 and 33 Fig. 1-21). The adjustments must be performed using a digital differential manometer with a scale in tenths of mm or Pascal. The power data in the table has been obtained with intake-exhaust pipe

measuring 0.5 m in length. Gas flow rates refer to heating values below a temperature of 15°C and at a pressure of 1013 mbar. Burner pressure values refer to use of gas at 15°C.

HEAT OUTPUT		METHANE (G20)			BUTANE (G30)			PROPANE (G31)		
		BURNER GAS FLOW RATE	PRESS. NOZZLES PRESSURE		BURNER GAS FLOW RATE	PRESS. NOZZLES PRESSURE		BURNER GAS FLOW RATE	PRESS. NOZZLES PRESSURE	
(kW)	(kcal/h)	(m <sup>3</sup> /h)	(mbar)	(mm H <sub>2</sub> O)	(kg/h)	(mbar)	(mm H <sub>2</sub> O)	(kg/h)	(mbar)	(mm H <sub>2</sub> O)
32,0	27520	3.45	8.30	84.6	2.58	8.40	85.7	2.53	8.20	83.6
31,0	26660	3.34	7.80	79.6	2.49	7.88	80.4	2.45	7.76	79.2
30,0	25800	3.23	7.33	74.7	2.41	7.39	75.3	2.37	7.34	74.8
29,0	24940	3.12	6.87	70.0	2.33	6.91	70.4	2.29	6.93	70.7
28,0	24080	3.01	6.43	65.5	2.25	6.45	65.8	2.21	6.53	66.6
27,0	23220	2.90	6.00	61.2	2.16	6.01	61.3	2.13	6.15	62.7
26,0	22360	2.79	5.60	57.1	2.08	5.59	57.0	2.05	5.78	58.9
25,7	22078	2.76	5.47	55.7	2.06	5.45	55.6	2.02	5.66	57.7
24,0	20640	2.58	4.83	49.2	1.92	4.80	48.9	1.89	5.07	51.7
23,0	19780	2.47	4.47	45.6	1.84	4.43	45.1	1.81	4.73	48.3
22,0	18920	2.36	4.12	42.0	1.77	4.07	41.5	1.74	4.41	45.0
21,0	18060	2.26	3.79	38.7	1.69	3.74	38.1	1.66	4.10	41.8
20,0	17200	2.15	3.47	35.4	1.61	3.41	34.8	1.58	3.79	38.7
19,0	16340	2.05	3.17	32.3	1.53	3.11	31.7	1.50	3.50	35.7
18,0	15480	1.94	2.88	29.4	1.45	2.81	28.7	1.43	3.21	32.8
17,0	14620	1.84	2.61	26.6	1.37	2.54	25.9	1.35	2.94	30.0
16,0	13760	1.73	2.34	23.9	1.29	2.28	23.2	1.27	2.68	27.3
15,0	12900	1.63	2.09	21.3	1.21	2.03	20.7	1.19	2.42	24.7
14,0	12040	1.52	1.86	18.9	1.14	1.80	18.3	1.12	2.18	22.2
13,0	11180	1.42	1.63	16.7	1.06	1.58	16.1	1.04	1.94	19.8
12,0	10320	1.31	1.42	14.5	0.98	1.37	14.0	0.96	1.71	17.5
11,0	9460	1.20	1.23	12.5	0.90	1.18	12.1	0.88	1.50	15.3
10,0	8600	1.10	1.04	10.6	0.82	1.01	10.3	0.81	1.29	13.1
9,0	7740	0.99	0.87	8.9	0.74	0.85	8.6	0.73	1.09	11.1
8,0	6880	0.88	0.71	7.3	0.66	0.70	7.1	0.65	0.90	9.2
7,0	6020	0.78	0.57	5.8	0.58	0.57	5.8	0.57	0.72	7.3
6,0	5160	0.67	0.43	4.4	0.50	0.45	4.6	0.49	0.55	5.6
4,5	3835	0.50	0.26	2.6	0.37	0.30	3.1	0.37	0.30	3.1
4,0	3440	0.45	0.21	2.1	--	--	--	--	--	--

### 3.19 COMBUSTION PARAMETERS.

		G20	G30	G31
Supply pressure	mbar (mm H <sub>2</sub> O)	20 (204)	29 (296)	37 (377)
Gas nozzle diameter (8205 gas valve)	mm	5.60	4.00	4.00
Gas nozzle diameter (848 gas valve)	mm	5.40	3.95	3.95
Flue flow rate at nominal heat output	kg/h	51	46	53
Flue flow rate at min heat output	kg/h	7	7	8
CO <sub>2</sub> at Nom Q./Min.	%	9.50 / 8.90	12.20 / 11.10	10.50 / 10.20
CO with 0% O <sub>2</sub> at Nom Q /Min.	ppm	190 / 7	600 / 1	250 / 5
NO <sub>x</sub> with 0% O <sub>2</sub> at Nom Q /Min.	mg/kWh	51 / 19	200 / 22	61 / 25
Flue temperature at nominal output	°C	60	66	60
Flue temperature at minimum output	°C	51	54	52

INSTALLER

USER

MAINTENANCE TECHNICIAN

## 3.20 TECHNICAL DATA.

Nominal heat input	kW (kcal/h)	32.6 (28042)
Minimum heat input	kW (kcal/h)	4.2 (3648)
Nominal heat output (useful)	kW (kcal/h)	32.0 (27520)
Minimum heat output (useful)	kW (kcal/h)	4.0 (3440)
Efficiency 80/60 Nom./Min.	%	98.1 / 94.3
Efficiency 50/30 Nom./Min.	%	106.5 / 105.3
Efficiency 40/30 Nom./Min.	%	107.7 / 105.9
Heat loss at casing with burner On/Off (80-60°C)	%	0.48 / 0.30
Heat loss at flue with burner On/Off (80-60°C)	%	0.03 / 2.20
Central heating circuit max. operating pressure	bar	3
Central heating circuit max. operating temperature	°C	90
Adjustable central heating temperature (max work field)	°C	20 - 85
System expansion vessel total volume	l	5.8
Expansion vessel factory-set pressure	bar	1.0
Water content in generator	l	5.7
Head available with 1000 l/h flow rate	kPa (m H <sub>2</sub> O)	31.0 (3.16)
Hot water production useful heat output	kW (kcal/h)	32.0 (27520)
Domestic hot water adjustable temperature	°C	30 - 60
Domestic hot water flow limiter	l/min	Automatic
Min. pressure (dynamic) domestic hot water circuit	bar	0.3
Domestic hot water circuit max. working pressure	bar	10
*Specific capacity "D" according to EN 625	l/min	16.4
Flow rate capacity in continuous duty (ΔT 30°C)	l/min	16.1
Domestic hot water performance classification according to N 13203-1		★★★
Weight of full boiler	kg	51.6
Weight of empty boiler	kg	45.9
Electrical connection	V/Hz	230 / 50
Power input	A	0.78
Installed electric power	W	110
Pump consumption	W	70
Fan power consumption	W	33
Equipment electrical system protection	-	IPX5D
Temperature of combustion products	°C	75
NO <sub>x</sub> class	-	5
Weighted NO <sub>x</sub>	mg/kWh	29
Weighted CO	mg/kWh	13
Type of appliance	C13 / C13x / C33 / C33x / C43 / C43x / C53 / C63 / C83 / C93 / C93x / B23p / B33	
Category	II 2H3B/P	

- Flue temperature values refer to an air inlet temperature of 15°C and delivery temperature of 50°C.
- The data relevant to domestic hot water performance refers to a dynamic inlet pressure of 2 bar and an inlet temperature of 15°C; the values are measured directly at the boiler outlet considering that to obtain the data declared mixing with cold water is necessary.
- The max. sound level emitted during boiler operation is < 55dBA. The sound level value is referred to semianechoic chamber tests with boiler operating at max. heat output, with extension of flue gas exhaust system according to product standards.
- \* Specific capacity "D": domestic hot water flow rate corresponding to an average increase of 30K, which the boiler can supply in two successive withdrawals.



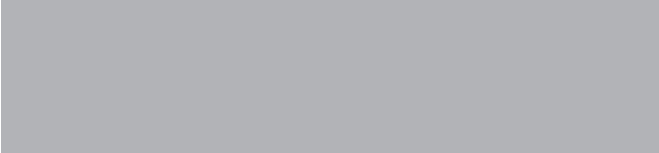

**Immergas S.p.A.**  
42041 Brescello (RE) - Italy  
T. +39.0522.689011  
F. +39.0522.680617

**[immergas.com](http://immergas.com)**



This instruction booklet is made of ecological paper.  
*Code 1.032471IE rev. 15.036945/001 - 09/2012*